

2019

Fire safety of rectangular hollow section (RHS) truss members with local imperfections

Bailey, L.

Bailey, L. (2019) 'Fire safety of rectangular hollow section (RHS) truss members with local imperfections', *The Plymouth Student Scientist*, 12(1), p. 187-206.

<http://hdl.handle.net/10026.1/14686>

The Plymouth Student Scientist
University of Plymouth

All content in PEARL is protected by copyright law. Author manuscripts are made available in accordance with publisher policies. Please cite only the published version using the details provided on the item record or document. In the absence of an open licence (e.g. Creative Commons), permissions for further reuse of content should be sought from the publisher or author.

Fire safety of rectangular hollow section (RHS) truss members with local imperfections

Luke Bailey

Project Advisor: [Dr Shanshan Cheng](#), School of Engineering, Plymouth University, Drake Circus, Plymouth, PL4 8AA

Abstract

This project investigates the effect of local imperfections on RHS truss members at elevated temperatures. The specific model used represents a realistic example of a RHS practical application and shows that local imperfections can have a detrimental effect on overall compressive resistance. Modelling showed that above 400°C, a member with a local imperfection will experience global buckling and failure significantly quicker than a member without. In consequence, this paper concludes that all slender RHS members that are defined as a key element should be given suitable fire protection.

Introduction

It is clear that when a structural member is subject to a local imperfection, its overall strength can be compromised. This project aims to analyse what the impact of a local imperfection is on a rectangular hollow section (RHS) when exposed to fire conditions. The local imperfections considered in this project will be those introduced by a X connection at the mid span of a relatively slender RHS truss member, referred to as 'class 3' in Eurocodes. The force applied to the connection is at fire limit state, as specified in Eurocodes. The compressive resistance of the member is tested and compared to a control model, where no local imperfections are present. The model is validated by comparing the section's compressive resistance at room temperature to the design resistance calculated using Eurocodes. Analysis Systems programme, ANSYS Workbench, will be employed to create the model and perform all analysis.

So that conclusions can be drawn that are useful in reality, the model must be as close as possible to an actual manufactured span of the same section. This means that it must encompass a fair representation of the small, global imperfections that are introduced in real-world manufacture. These global imperfections will be introduced using techniques suggested by Eurocode 3.

It is expected that a steel RHS truss member subject to a local imperfection in a fire will perform significantly worse than the same member with no local imperfection. This project aims to prove this as well as quantify how much variation a local imperfection can cause. The section that is selected to be modelled will have the same dimensions as a standard section that is readily available in the UK, except it will be modelled with thinner walls. The wall thickness will be reduced from a standard thickness until it is slender enough to be class 3. By using a thinner than standard section, if the model performs better than expected, it may be possible to make a recommendation that class 3 RHS sections are still useful when exposed to fire conditions.

It is known that elevated temperatures cause most materials to experience a decrease in Young's modulus as atom bonds become easier to stretch. Properties of steel at elevated temperatures are calculated using Eurocode reduction factors applied to the properties of steel at room temperature. S355 steel will be tested and the model will run temperatures up to 700°C.

Literature Review

Review Scope

The aim of this literature review is to research material related to the title topic, provide a rounded knowledge of the field and allow a narrowing of future research to what is deemed most important. Hollow steel structures are becoming increasingly popular in modern construction and it is important to know how such structures will perform in fire situations. This review will investigate how rectangular hollow sections perform at elevated temperatures, specifically when they have been subjected to local imperfections.

Specifically, the scope of this project will focus on imperfections caused by truss X connections loaded to fire limit state. The member to be tested will be a semi-

compact, class 3 section, edging towards being a slender, class 4 section. This type of section is susceptible to local buckling and is likely to buckle due to the imperfection caused by the connection.

The historic development and importance of RHS members in modern construction will also be considered. This literature review is divided into four main sections and will aim to identify techniques to be used in the modelling and validation stages of the project.

RHS Tubular Sections & Connections

Rectangular tubular sections were originally developed by Stewarts and Lloyds (now Corus Tubes) as an alternative to circular tubular sections (Wardenier, 2010). The straight sides of what is now known as an RHS member eased the connection and welding process whilst keeping the advantages and similar properties of a circular hollow section. Compared to the earlier developed circular section, the straight sides of the RHS meant minimal face preparation was required for joining.

RHS members can be used for a wide variety of applications across all types of construction and are often preferred because of their aesthetic quality, versatility and strength. As one of the top steel producing companies globally, Tata Steel, mention on their website, 'Many of the strongest and most impressive structures in the world today would not have been possible without hollow sections' (Tatasteeleurope.com, 2017). Hollow sections are highly regarded in modern construction because of their ability to cope with loading in multiple directions. RHS members have efficient shapes for multiple-axis loading due to their uniform geometry along two cross-sectional axes (Zhao, Wilkinson and Hancock, 2005). The shape also provides excellent resistance to torsion.

Two widely used design methods for RHS tubular sections and their connections can be found in the CIDECT design guide and Eurocode 3. For tubular X – joints, Eurocode and CIDECT provide two different equations for connection resistance. (β = ratio of brace diameter to chord diameter)

CIDECT (For $\beta=1$):

$$N_1 = \frac{f_k t_0}{\sin \theta_1} \left[\frac{2h_1}{\sin \theta_1} + 10t_0 \right]$$

EC3 part 1.8 (For $\beta=1$):

$$N_{1,Rd} = \frac{f_b t_0}{\sin \theta_1} \left(\frac{2h_1}{\sin \theta_1} + 10t_0 \right) / \gamma_{M5}$$

Where: f_b and f_k relate to the chord's side wall flexural buckling stress, t_0 is the chord thickness, h_1 is the depth of brace member, θ_1 is the angle of the cord to the brace (90 degrees when perpendicular), γ_{M5} is the partial safety factor (1.0 in Eurocode) and N_1 is the design strength. Although the equations are similar and give comparable results, there will be slight differences due to the different safety factors built into each design code.

Today, in typical uses for RHS members, design is often dictated by the want for slender, lightweight structures to aid transportation and aesthetics (Degée, Detzel

and Kuhlmann, 2008). For these slender, lightweight structures, members will have thinner walls of high strength steel and will be more susceptible to local buckling which may cause the overall capacity to be reduced. Eurocode three defines such sections as Class 3 & 4 and there are two methods for taking into account the effects of the local buckling when designing. The methods are known as: the effective width method and the reduced stress method. The reduced stress method uses a reduction factor, $\frac{\lambda_{sy}}{\lambda_s}$, where λ_{sy} is the defined yield slenderness limit and λ_s is the plate element slenderness (Ma, Chan and Young, 2017). The effective width method is based on the fact that local plate buckling will reduce the effectiveness of the plates that make up the cross-section and works by reducing the width of each flat compression element by taking off any width in excess of the width corresponding to λ_{sy} . Ma, Chan and Young (2017) evaluated the two methods and concluded that the reduced stress method is more conservative, and that the effective width method will be more accurate.

An alternative method, not included in Eurocode, to help determine nominal axial, flexural and shear strengths of cold-formed steel members is known as the direct strength method. It is, 'essentially an extension of the use of column curves for global buckling, but with application to local and distortional buckling instabilities,' (Schafer, 2008). It is noted that the reliability of the direct strength method is as good if not better than the effective width method. The direct strength method is becoming increasingly popular because using the effective width method is calculation-intensive and time-consuming because of the non-uniform distributions of mechanical properties of steel.

Fire Safety/Design

As mentioned in section 1.2, the effective width method is a useful approach described in Eurocode 3 for class 4 sections. At elevated temperatures, the same concept can be used with some changes specified in Annex E, Part 1.2 of Eurocode three. It suggests using the normal calculation methods but using the steel yield strength at 0.2% proof strength instead of the strength at 2% total strain as usually done in fire design of other classes. It is also noted that using a reduced value of ϵ in fire situations can lead to a higher section classification but will prevent the classification changing for every temperature (Couto et al., 2014).

When designing a structure for fire conditions, it is expected that the load ratio will be somewhere between forty and sixty percent of the ultimate limit state. This is called the fire limit state and the exact figure can be calculated using the load ratio which takes into account the Eurocode's various load factors at normal and elevated temperatures. The design force at the fire limit state is significantly lower than that at the ultimate limit strength because it is so unlikely that the maximum possible loading will occur at the same time as a fire. In fire situations, the aim of the structure is not only to retain its structural integrity, but also allow all persons to exit the building safely and unharmed.

Eurocodes 3 and 4 demonstrate methods to achieve a required degree of fire resistance for steel. Three levels of calculation are shown: tabular methods, simple calculation models and advanced calculation models (Lawson and Newman, 1996). The tabular methods can be restrictive due to their design tables only covering

common design cases. In modern construction, it is likely that computer models would be used to implement the other methods. It is therefore important to be able to validate computer results. A method to testing the finite element model was put forward by Ozyurt, Wang and Tan in 2014. The method involves adjusting values in load resistance equations in different design codes and comparing results to finite element model output.

Results of the numerical simulation are compared with calculation results using the design equations in Eurocode 3 and the committee for international development and education on construction of tubular structures' (CIDECT) design guide (some equations shown in section 1.1). This is achieved by substituting the yield stress of steel at ambient temperature by those at elevated temperatures (Ozyurt, Wang and Tan, 2014). The paper concludes that the approach is only suitable for certain types of joints and not for X-Joints under brace compression loads. The method's results do follow the expected trend but overestimates the ultimate load capacity of the joint (Ozyurt, Wang and Tan, 2014). The paper notes that the strength of the joint closer matches the reduction of the elastic modulus as the temperature is increased. Although the above method for validating results is inaccurate, it is recommended that for T, Y and X joints with brace members in compression, the connection's resistance should be adjusted by the steel Young's modulus reduction factor at the elevated temperature.

Buckling

Buckling can occur when a member is subjected to compressive stress and is identified by a sudden sideways deflection. It may occur even when the stresses are far less than the value needed to cause the member's material to fail. The width to thickness ratio (b/t) will have a large impact on how the structural member will fail. In a RHS truss member, a brace member can cause a minor deformation when transferring its load through. This acts like a local buckling to the chord member. Kwon and Seo (2013) investigated the subject and concluded that the interaction between local buckling and global buckling has a, 'significant negative effect on the ultimate strength'. It is likely that this conclusion would be comparable to a similar experiment but with elevated temperatures, however, more investigation is clearly necessary to determine what the trend would be.

Local Imperfection Modelling

Local buckling is most sensitive to local imperfections which makes it very important to accurately model such imperfections (Rendall and Rasmussen, 2015). According to Schafer and Peköz, (1998), there is not a consensus on what distributions or magnitudes should be used for modelling imperfections in cold-formed steel members so it is important to review techniques and select the most appropriate. Since 1998, methods have developed and there are preferred methods for various situations.

Because it is very difficult to measure real imperfections, theoretical imperfections are usually preferred in computer modelling. Eigenmodes of elastic buckling can be calculated using finite element methods. Periodic model, sine shapes or a combination is what is usually used to represent shapes (Sadovský et al., 2012).

Another theoretical method proposed by Rendall and Rasmussen (2015) was to model geometric imperfections using the wavelet transform. They noted that the models using wavelet frames performed as well, if not better than models using a more traditional Fourier series expansion. Rendall and Rasmussen (2015) do note, however, that edge effects will arise and can often introduce discontinuities in the analysis.

Computer Modelling, Principles of Methods

Finite element analysis, FEA, is a numerical method that is widely used in most engineering disciplines. Computer modelling with programmes using FEA is common but it is important to note limitations and areas that can cause error. FEA errors fall in to three general categories: user error, modelling error and discretization error (Pointer, 2017).

Modelling error describes any differences between the model used for analysis and the real-world equivalent (Pointer, 2017). Some of these differences will be necessary either because it is impossible to achieve a perfect model or because the analysis model has been simplified to reduce model running time.

Discretization error relates to the mesh and can be sub-categorised into two main parts: the element type and the mesh convergence (ESTEQ, 2017). If the element type is solid it will have the potential to be the most accurate due to its ability to, 'calculate a complete 3D stress state at each node in the model.' (ESTEQ, 2017). In most plate structures the stress through the thickness is small enough to be ignored but there will be a small error. Instead of a solid model, a shell element can be used to represent a structure element. In practice, when modelling a RHS truss member, a shell element is likely to suffice and will reduce model run time but a comparison between the two would be advised.

Mesh convergence is a reflection of how accurately the discretization represents reality. Shah (2002) offers some guidelines on how to validate a model and its mesh using experience, however, the paper explains, 'the only true indication of an accurate solution is to perform convergence studies by increasing the element count in the model and assuring that the result of interest is graphically converging to a stable value' (Pointer, 2017).

Literature Review Conclusion

It is clear that there is a gap in knowledge and publications related to RHS members in fire conditions. Multiple papers (some referenced in this review) investigated the interaction of local buckling and global buckling, however, there is less information on such interactions at elevated temperatures. In particular, there is little research on how initial local imperfections caused by a brace joint will affect the overall compressive resistance once temperatures are raised. It is therefore important to focus future studies on this subject, using techniques from previous research as guides.

Section Properties, Buckling and Imperfections

Section Classification

Section classification is a term that refers to the different types of class a section can belong to, depending on how slender it is. Eurocode defines Class 1 as the least slender and least susceptible to buckling and Class 4 as the slenderest and most susceptible to buckling. It is important to know how sections in each class behave and what they are suited to. Calculations conclude that the section is class 3 with a 3mm thickness.

The standard thicknesses of larger RHS sections are thick enough to put almost all into the Class 1 or 2 category. A possible reason for this could be that not enough research has been put into RHS class 3 and 4 sections, and they are therefore riskier to use, for fear of buckling at elevated temperatures. For this project, sections with thicknesses smaller than that of the standard sections have been used. The reason for this is to see how susceptible steel truss members are to buckling, when slenderer than usual sections are used. If the results show that a slenderer section with local imperfections can still hold a reasonable load at elevated temperatures, it would suggest that thinner sections are still useful. This could mean that certain structures could have costs reduced through less steel being vital to the integrity of the structure.

Imperfections

Truss members are likely to have small, local imperfections at the point in their span where brace members are transferring load through the main section. A similar, representative imperfection must be added to the ANSYS model to see the effect on overall compressive resistance. On ANSYS, the imperfection could be added in a number of different ways, this project used remote forces and the method is described in the, 'Geometry & Model' section. When running the model, the remote force will be applied before the global compressive force is applied.

Although this project aims to focus on the effect of local imperfections, for an accurate model, it is also important to consider global imperfections. Global imperfections in practice can be small defects in geometry, introduced in manufacture. These imperfections need to be included in model geometry to accurately represent reality. There are many different methods of including imperfections in an ANSYS model, some discussed in the literature review. The model used in this project utilised Eurocode's method of introducing relative, initial local bow imperfections. This method takes into account the type of steel and gives a recommended bow in the given span that is a reasonable representation of the real-world effects of residual stresses and geometrical imperfections. This bow can then be included in the model geometry by extruding in an arc shape with the desired bow length at the mid span. Once this global imperfection has been introduced, results from the model will be more accurate, and, most importantly, will not greatly overestimate the compressive resistance of the member. The initial bow used for the 3m span in the model was 20mm and the calculation for this is attached in Appendix 2.

Buckling

When a compressive stress is applied to a member, it is at risk of buckling. Buckling can often be identified because there will be a sudden sideways deflection somewhere in the member. This sudden deflection can happen due to stresses that occur in the structure even if those stresses are significantly smaller than the material's specific failure point. Buckling can cause failure before it is expected in the material, which is dangerous and therefore requires in depth analysis to identify the point at which the structure may be vulnerable. Class 3 and 4 sections are defined by the Eurocode as being more susceptible to buckling due to their relative slenderness. Global buckling is defined as the failure mode where the member deforms with no deformation in its cross-sectional shape. Local buckling is usually described as the failure mode in which there are plate-like deformations alone.

Design Values

All values used are calculated using Eurocodes.

Connection Force

The connection force is applied to the mid span of the section and represents the force transferred through the span by brace members. The brace members are part of an X connection and join the main span at a 90° angle. A sketch of the connection can be seen in Figure 1.

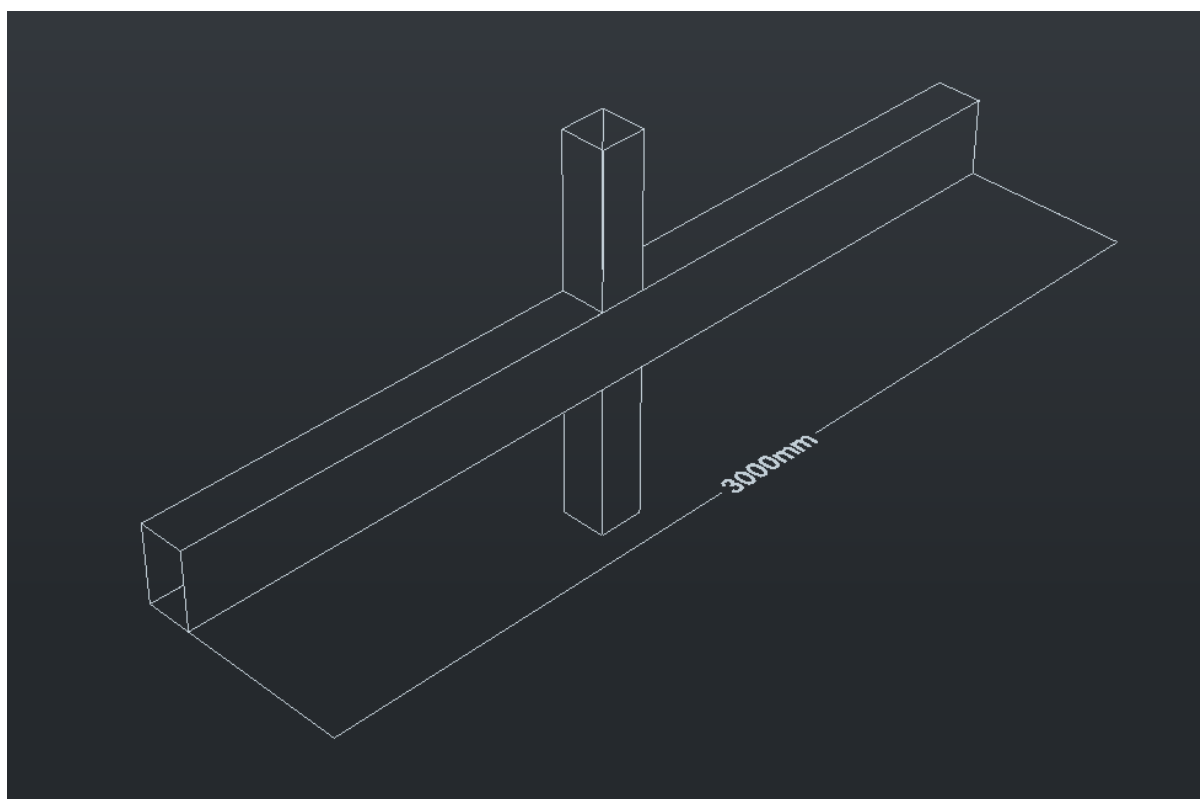

Figure 1: Sketch of span and connection to be tested.

The maximum load that the connection can transfer is defined in CIDECT's design guide for RHS joints under predominately static loading. An example calculation for this can be seen in Appendix 2. The CIDECT guide gives the maximum load that can be transferred at room temperature. Eurocode states that in the event of a fire, the

structure must support a reduced, 'fire limit state' of loading. This is because there is unlikely to be loading anywhere near the ultimate limit during a fire. Eurocode suggests using approximately 40% of the ultimate limit state for the fire limit state. For this particular project, the connection load calculated using the CIDECT design guide must be reduced by multiplying by 0.4.

Modelling Method

ANSYS Workbench 18.1 was used to perform a static structural analysis on the RHS section.

Engineering Data

For a successful and accurate model analysis, it is vital that all data inputted into the model is correct. In ANSYS, material information is inputted in the 'Engineering Data' tab of static structural analysis window. ANSYS does have a library of material properties that can be implemented, however, extra information is often required. For this particular project, ANSYS's standard properties for structural steel were employed with some changes and additions. The values for yield strengths were changed to match the specific type of structural steel chosen for the design, which was S355 steel. Bi-linear Isotropic Hardening values were also added to the material properties for the structural steel used in the model. A bilinear stress-strain curve requires that the yield strength and tangent modulus are inputted. The slope of the first segment in the curve is equivalent to the Young's modulus of the material while the slope of the second segment is the tangent modulus. This information relates to how the material behaves after it has passed the yield point.

ANSYS holds material properties for many materials at room temperature, however, for analysis at elevated temperatures, information regarding how the material performs at various temperatures must be inputted. To calculate the properties of structural steel at elevated temperatures, Eurocode 3, Part 1-2, specifies reduction factors for key properties in relation to the value at room temperature in Table 3.1. The table gives reduction factors for temperatures from 100°C to 1200°C in intervals of 100°C. To find the factor for a temperature in between intervals, the table states that linear interpolation may be used. The reduction factors were applied to the yield strength, tangent modulus and young's modulus for temperatures ranging from 200°C to 800°C, these values are shown in appendix 2. The other value that must be input for each temperature interval is the Poisson's ratio, which is temperature independent and has a value of 0.3 (Lawson and Newman, 1996).

Some material properties are not specified in ANSYS's engineering data but are needed to calculate values from Eurocode. To calculate the imperfections required by Eurocode to represent reality, the way the steel is formed must be determined as dictates which buckling curve to use in Table 5.1 of Eurocode 3, Part 1-1. The steel used in this project has been selected as cold formed. Cold forming steel is a cheaper method of manufacture and is usually used when the thickness is below 7mm, although some big manufacturing plants can cold form up to 19mm thick (Chen, 2018). The thickness of the section modelled in this project is 3mm so cold forming is the most suitable.

Mesh

Meshing is an intrinsic part of finite element modelling. Meshing defines the process of approximating a geometric domain for analysis purposes. The mesh dictates the level of accuracy, convergence and model running time. Selecting an appropriate mesh is key to having a successful model and a balance must be struck between detail and simplicity to ensure that the model gives results that are accurate to a reasonable degree but also takes a reasonable amount of time to run. A finer mesh is defined by having more nodes than a coarser mesh and, in general, the more nodes a model has, the longer it will take to run.

The mesh used in this project was created using ANSYS and is seen to be a polygonal mesh split into two different face mesh sizes. The mesh is split into two different face sizings, to allow certain key parts of the section to have a more detailed analysis, whilst allowing the rest to have a slightly coarser mesh. This allows a higher accuracy of results in the parts of the model where it is needed, without slowing down the model as much as if the whole section had the same, fine mesh.

It is important to first identify which parts of the model need what degree of accuracy. Because this project focuses on local imperfections caused by connections, the area around the connection must have a fine mesh. The remainder of the section is less subject to small local imperfections, so, it is acceptable to reduce the detail of the mesh in this section to quicken the overall run time of the model. Figure 2 shows that the finer mesh changes to a coarser mesh 75mm past the connection, which is a reasonable distance to still have the effects of the connection in more detail but not increase model run time too much.

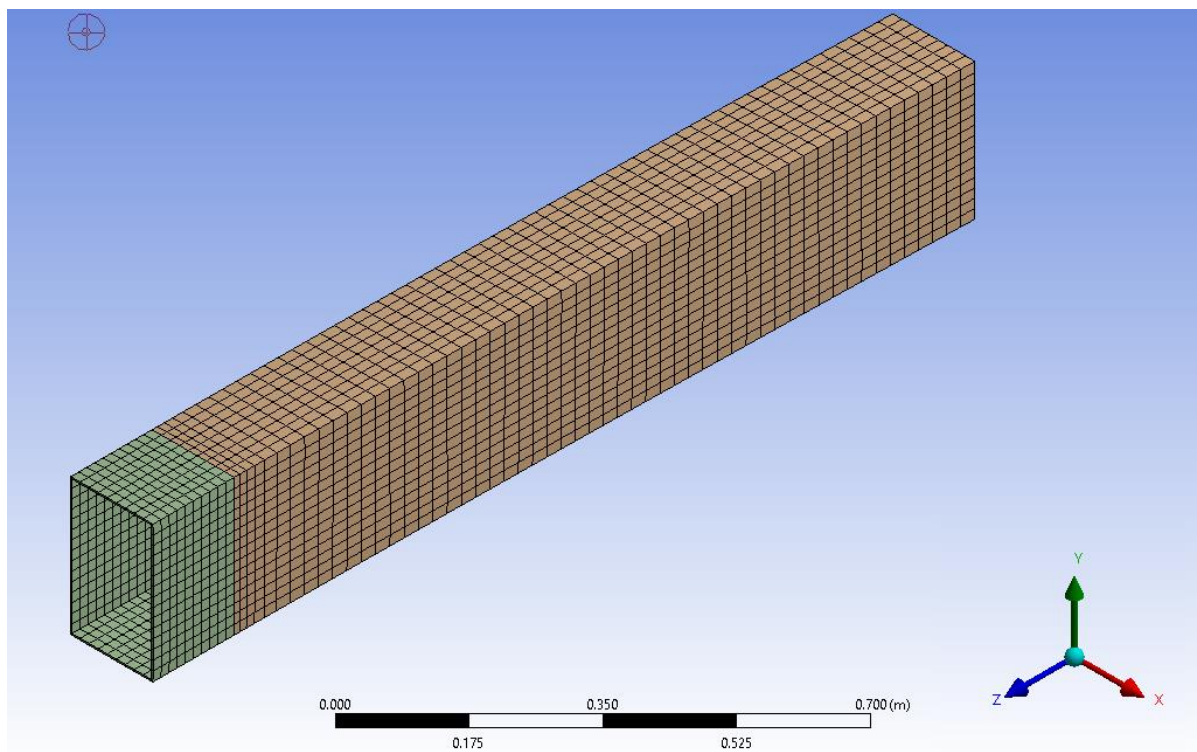

Figure 2: ANSYS Workbench Diagram showing split mesh.

Another way the mesh can be adjusted to suit the needs of a particular model is to have different element sizes in different planes. For the model used in this project, it

was more important to have detail in the y direction than in the z (span) direction. This is because the local imperfection caused by the connection is the key part of the model and this will mostly be represented in the y direction. It was therefore important to have more nodes in the y direction than the z, spanning direction. When using different element sizes in different directions, it is important to check that the mesh ratio is below 1:5 otherwise issues can arise. On ANSYS, the mesh sizing can be adjusted using the sizing tool. It can be set differently for different faces and directions.

Geometry & Model

The original outline was sketched using ANSYS DesignModeler. Firstly, the outline must be drawn on the XY plane. The bow at the mid span and the curve of the section that represents global imperfections must be introduced when extruding. The extrude can be made to follow a three-point curve, where the middle point is 20mm (desired bow depth) offset from the centre in the X direction. The extrude must then be split in half to become a half model, described in detail in the following section. The single part must then be split into two bodies to later allow the model to have two different types of mesh as described in the previous section. To create a shell geometry, the extrude is set to be a thin surface with a 0mm thickness. (Actual material thickness specified later)

Once the basic geometry is complete, the information must be transferred into the 'model' part of ANSYS's Static Structural system. From here, all forces, boundaries and meshes can be added. The thickness of the surface body must first be specified but can be changed at a later stage to see what effects the material thickness has on failure mode.

Using ANSYS, there are many ways to accurately represent the brace members transferring load through the truss chord. The model in this project uses remote forces. It is important to make sure that the remote forces act in such a way as to exactly match the effect of brace members. The particular nodes that the remote force will act on must be carefully chosen using ANSYS's named selection worksheet selection process. The remote point is placed a nominal distance above the nodes and act towards the centre of the section with an equal and opposite force being applied from below, this is represented in Figure 3. The arrows labelled A and B are the remote forces and the pink dots are the nodes upon which the remote forces act.

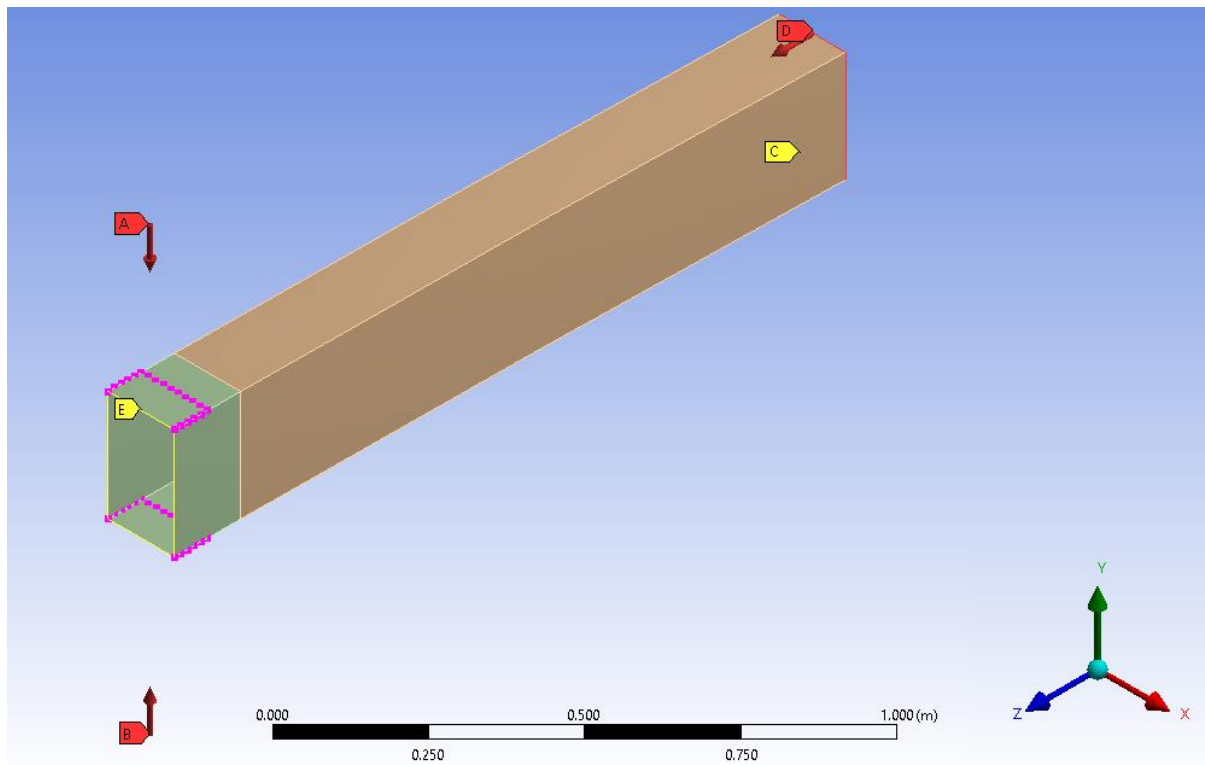

Figure 3: ANSYS Workbench Diagram of applied forces.
5.4 Half Model

Originally the model used in this project included the entire span of the truss chord with remote forces acting on the mid span to replicate the forces transferred by brace members in a X connection. Although the original model did run successfully, the issue with it was that the run time was unreasonably timely. Each time a part of the model was amended or adjusted, the model had to be left to run for a significant amount of time which slowed any progress. A decision was made early on to replace the model with a half model. This was possible due to the original model being symmetrical at the mid span in the z direction. The model was cut about the 4 edges labelled E in Figure 3.

For the model used in this project, symmetrical boundary conditions are represented on the symmetry plane as ($U_z=0$), ($U_y=free$), ($U_x=free$) and for rotation: ($R_z=free$), ($R_y=0$) and ($R_x=0$). These boundary conditions were achieved in the ANSYS model by selecting the four edges of the symmetrical plane and fixing their z component. By selecting all four edges, the desired rotation boundaries are also achieved.

Other factors must be taken into account to ensure a half model is an accurate representation of a full model. For symmetry to exist the conditions must also be met for the geometry of the component, the material properties of the component, and the loads applied to the component. The geometry of the component is satisfied because the symmetrical plane is at the mid-point. The material properties will not change on either side of the mirror so can be left unchanged, however, the load from the x connection must be halved. This is because the load transferred by the connection is split in half about the symmetrical plane.

It is important to understand the issues that can arise when using a half model to represent a whole model. For buckling analysis, a model can respond with symmetrical and anti-symmetrical mode shapes. A half model will only capture the symmetrical mode shapes and ignore any anti-symmetrical. For this particular project, because the focus is on the effect of small, local imperfections at the mid-point, the modes of failure caused by this are likely to be symmetrical and even if they are not, for example there is a torsional failure, seeing half of the model's results are sufficient to diagnose how the local imperfection is affecting the system. Another issue that can arise from using a half model instead of a full model is where remote forces will act. It is important to change the positioning of the remote point to be on the line of symmetry so as to accurately represent the full model.

Boundary Conditions

Other than the boundary conditions used at the mid-span to replicate a mirrored half model, boundary conditions must be set for the other end of the span to replicate, as close as reasonably possible, the cut between the model and the rest of the truss which is not included. To set these conditions, it is imperative to consider how the point at which the boundary is being set would interact with the rest of the truss if there was no boundary at all. The boundary condition at the end of span for the model should be a roller. This allows movement in the z direction but none in x or y and allows rotation in x and y but none in z. These conditions will replicate how the end of span would behave if it were a part of an entire truss. The required boundary conditions must then be applied in ANSYS in an appropriate fashion. For the model used in this project, the boundary condition of a roller was implemented by fixing one edge in the x and y direction, leaving the z direction free. By applying to one edge of the face, the rotational requirements of a roller are also satisfied.

When considering boundary conditions for a model that will experience fire conditions it is important to acknowledge thermal expansion and how it will affect the model. In practice, when a steel truss' temperature is raised, the entire structure is likely to expand a small amount. The model used in this project represents only a single member of a truss which means that although it would expand, it would not expand completely freely, as the rest of the structure would also be expanding and, therefore, try to push back. Because it would be difficult to set boundary conditions that perfectly match the behaviour in practice, conditions must be set that are a close approximation. It is then vital to understand how the approximation will affect the results. As mentioned above, the model used in this project uses a roller at one end of the span. A roller will allow movement in the z direction which means the model is completely free to thermally expand. Although this small difference from reality will make little impact, it is important to note that results will therefore show the member having slightly more compressive resistance than in practice. Acknowledgment of this minor flaw must be made when reviewing results.

Force VS Displacement

Using ANSYS, there are different methods to test a model's compressive resistance, and they have their own advantages and disadvantages. The first method is to simply apply a force to the member until it yields. For structural steel, this will show a linear stress/strain relationship up until the yield point. Because no further force can be resisted after the yield point, no further information will be gathered. Another approach would be to incrementally add deformation to one end of the member.

Comparatively to loading with force, the advantage of controlling the displacement is that the behaviour of the member after the yield point can be observed. This behaviour is non-linear and often crucial for determining how a structure will behave in a fire situation, as the yield point of steel is reached sooner at elevated temperatures. Eurocode (EN 1993-1-5) proposed that for plated structures, the strength retained after steel has been loaded past its yield point is 1% of its pre-yield strength. 1% of pre-yield strength is not enough to support fire limit state loading, therefore, in this particular case it is not useful to see the behaviour of the steel after its yield point. Because only the pre-yield behaviour of the steel is important, it is appropriate to load the model with force instead of displacement.

Modelling Method

See results shown in Appendix 1 and read in conjunction with the below.

F.L.S. Model

The F.L.S. Model loads the RHS truss member, with global imperfection, over two seconds and in two different ways. For the first second, the model only applies the fire limit state connection force at the mid-point. For the 2nd second, a compressive force is applied in the z direction. At 1 second into the runtime, there is a 0kN compressive force that gradually rises to 20kN when the model finishes running 2 seconds in. The model is run at room temperature (20°C), at 300°C and then every 100°C up to 700°C. An extra measurement is also taken at 550°C, to compare the strength retained to what is normally expected of steel.

The model's stress vs strain graph shows, as expected, linear lines that gradually experience more strain for the same amount of stress as the temperature is increased. The graph shows that between room temperature and 500°C, there is a small and similar change with each step increase in temperature. The 600°C stress vs strain line is a significant jump away, with the 700°C being another larger jump again (Shown in Figure 4). This large, significant change starting somewhere between 500°C and 600°C is to be expected as all steel stress vs strain graphs at elevated temperatures have a similar trend.

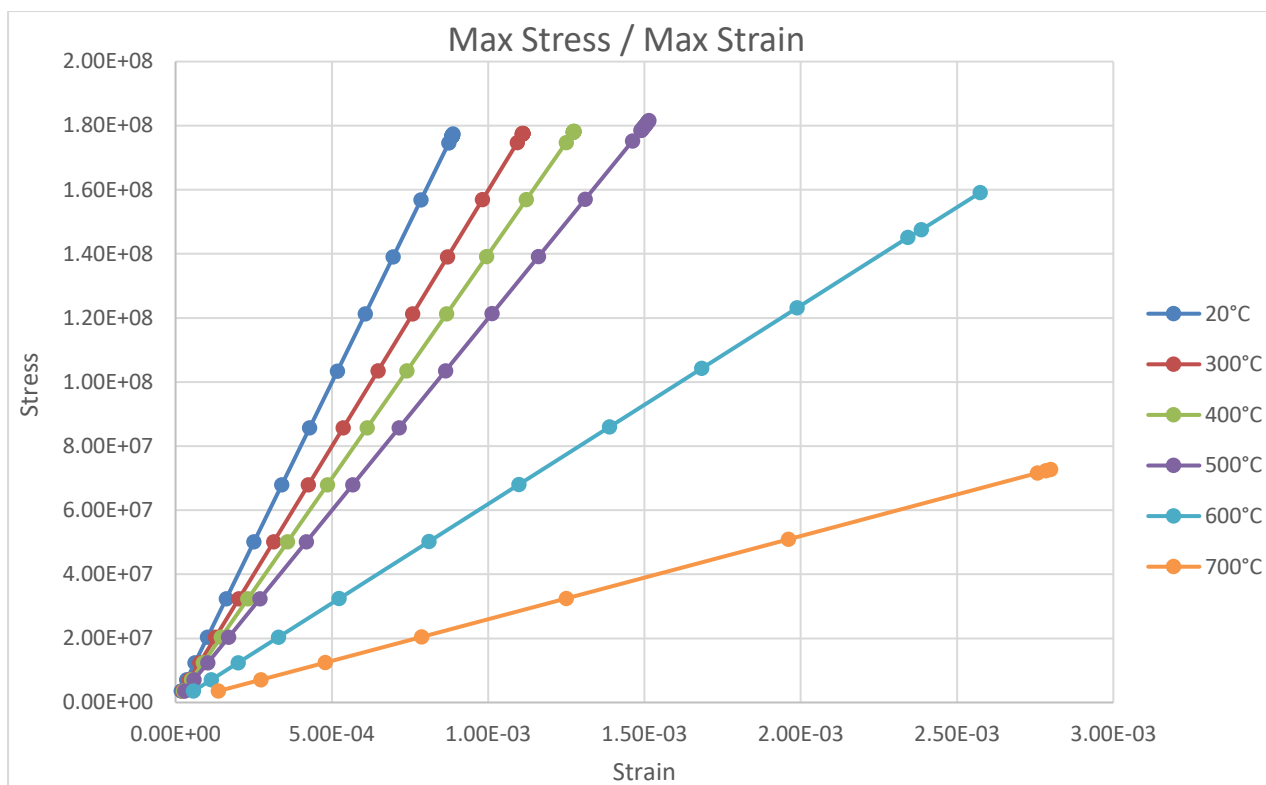

Figure 4: Stress Vs Strain Graph taken from ANSYS Workbench

The results for the 600°C model test show that the model loading stops at 0.8525 seconds. This is because the model has failed. Failing before the 1 second mark means that it has failed with the force applied by the connection alone. It therefore can hold no compressive force what so ever. At 700°C, the model fails at 0.3919 seconds which means, at such a temperature, the section can't even support half of the fire limit state connection force. From the test run at 700°C, it is reasonable to assume that any tests run at a higher temperature would show the model failing almost instantly as the connection force is applied, for this reason, further testing at higher temperatures is unnecessary.

The deflected shape of the model when run at 500°C shows that the largest amount of deflection is along the top flange of the RHS section, not at the mid-span where the local imperfection was applied. This is also true of all models tested below 500°C and is shown in Figure 5. The highest levels of stress and strain, however, are at the mid span and clearly due to the local imperfection. This can be seen in Figures 6 and 7, exports from ANSYS showing levels of stress and strain represented by varying colour.

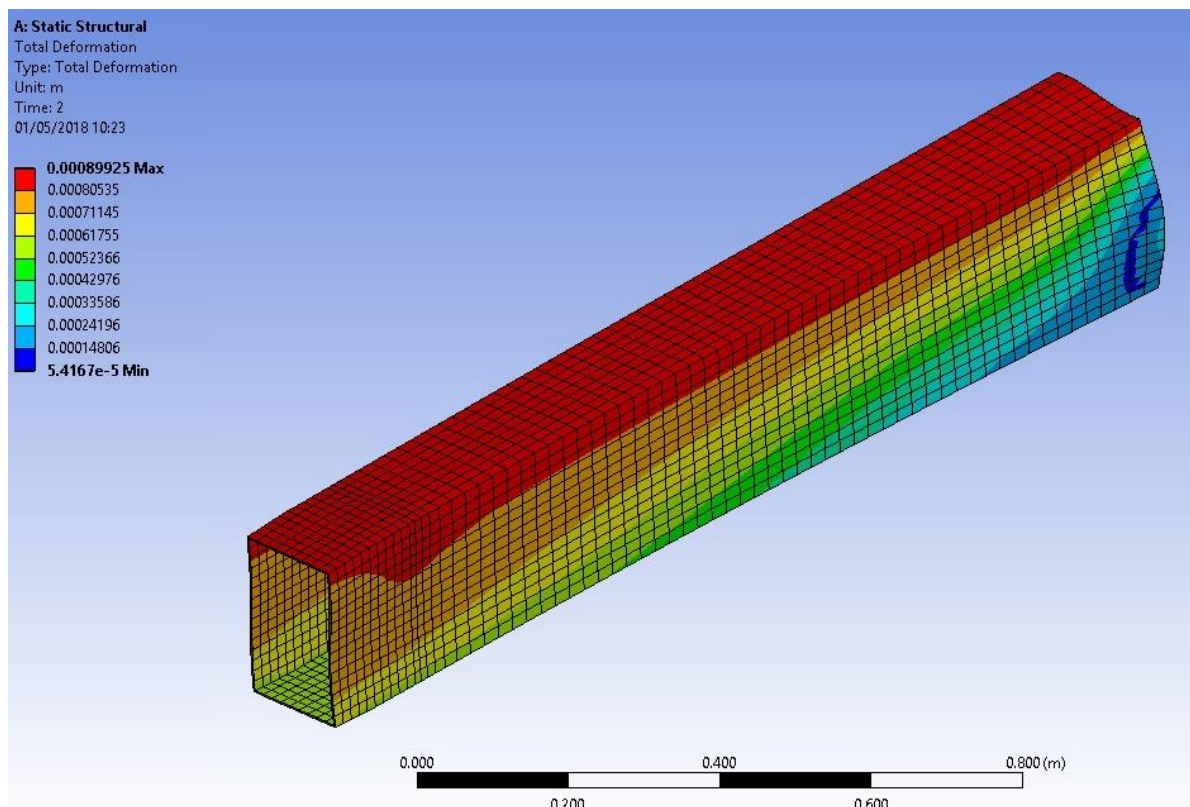

Figure 5: ANSYS Workbench Diagram of Total Deflection (At 500°C)

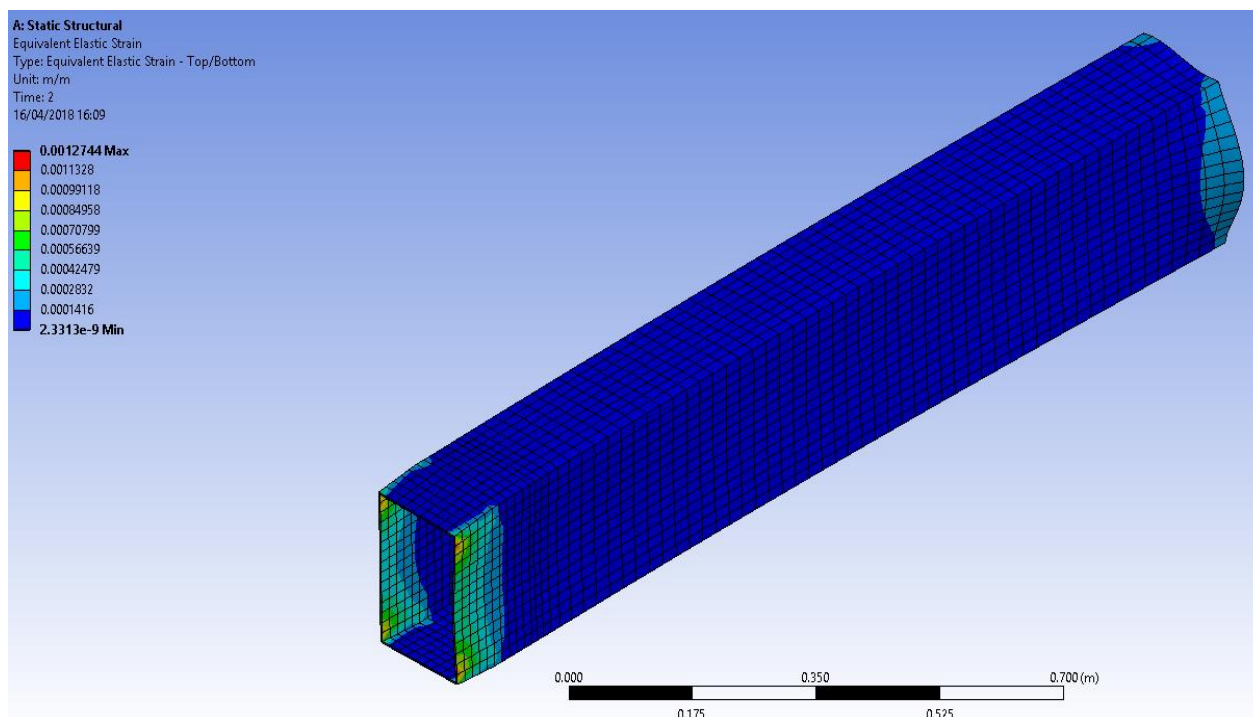

Figure 6: ANSYS Workbench Diagram of Elastic Strain

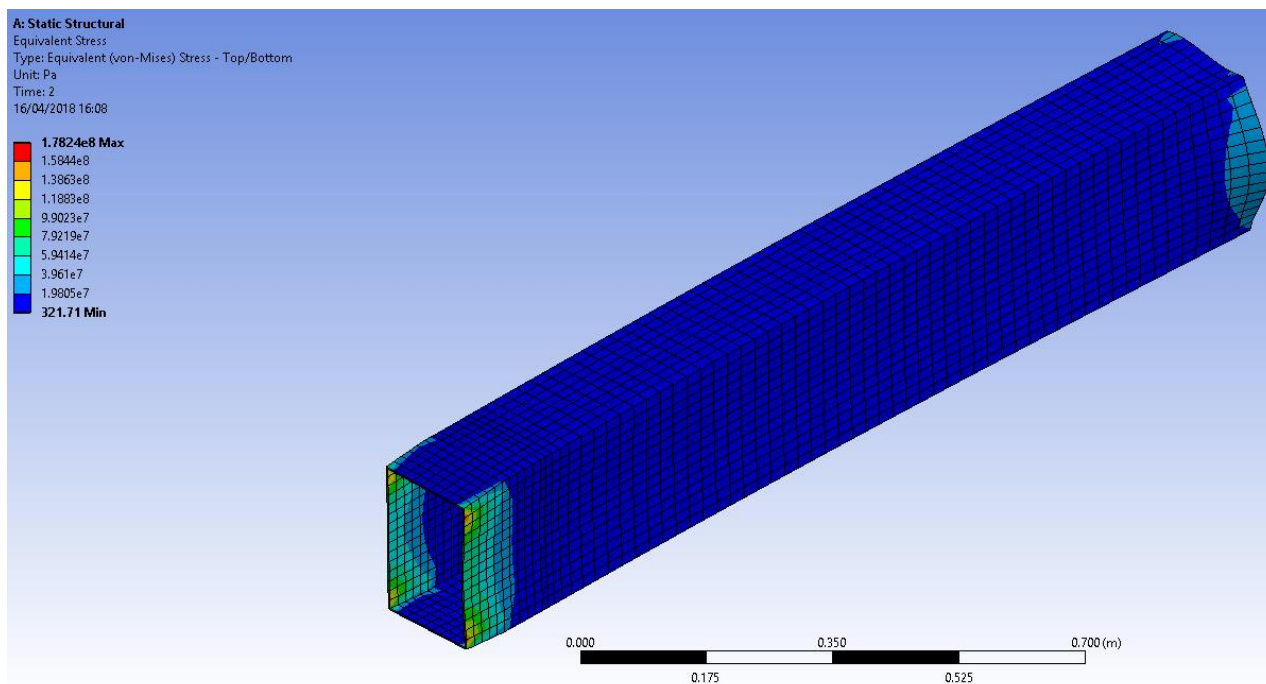

Figure 7: ANSYS Workbench Diagram of Stress

Control Model

The control model to be used for comparison is set up identically to the F.L.S. model except for the fact that it has had the connection forces suppressed. This means that there is no force acting on the system for the first second of the run time. This is why there is zero displacement up to one second on all time vs displacement graphs showing control test results. The stress vs strain graph produced using the control model data shows a very similar general shape to that of the F.L.S. model. The only real difference being the magnitude of the graphs as the lack of connection force reduces the stress and strain significantly.

With no connection force, the control model does not fail and takes full compressive loading up to when the model stops at 2 seconds. The time vs displacement graphs do clearly show that as the temperature increases, the deflection increases for the same amount of force. This is to be expected as the properties at elevated temperatures have had reduction factors applied, meaning the compressive strength has reduced.

Review

Comparison of F.L.S. and Control Models

The time vs displacement graphs (Found in Appendix 1) show that the line of best fit after 1 second, is similar for all graphs representing data from models tested up to 500°C. As the temperature increases, the values do start to differ more and more, however, up to 400°C, they are approximately within 10%.

Up to 400°C, the graphs show that the control model actually has a higher deflection than the model that includes a connection force. This reverses between 400°C and

500°C, where the deflection then becomes rapidly higher in the model with a connection force. At temperatures above 550°C, the connection force fails the system before the global compression force has started to have an impact, meaning its compressive resistance is close to nothing.

Both models make the assumption the heat is evenly distributed across the section and span. In a real-world application, it is unlikely that the temperature distribution would be perfectly uniform, however, to perfectly model a specific situation, more details would need to be known. The models used in this project give a general, representative case.

Validation

To validate the models used to obtain results, one of their results must be compared to an already tested and proved result. This tested result can be a value found using a proven design code. To validate the model used in this project, comparison will be made to a Eurocode design value. The value to be compared will be the compressive resistance in the z direction with no connection forces being applied. The model's result will be taken from a test at room temperature (20°C), this is because Eurocode's design value will also be for room temperature.

It is to be expected that the compressive resistance will be slightly overestimated in the model results compared to the Eurocode design value. This is due to thermal expansion being left free in the model, as described under the, 'Modelling Method' heading.

The Eurocode design value for the compressive resistance of the member is 143kN (Calculation shown in Appendix 2.) When the model is run at room temperature, it fails at 164kN. As expected, the model has overestimated the force compared to the design value. The two values, however, are within 14.7%, which shows a fairly strong correlation and validates the model to a reasonable degree of certainty.

Conclusion

This project has presented the results and given methodology for multiple strength tests on RHS truss members at elevated temperatures, focusing on the effect of local imperfections. 550°C is the approximate known temperature that steel will retain 60% of its room temperature strength, which is enough to support the fire limit state load. The results from this project show that the control model with no local imperfections could support approximately 53% of room temperature strength at 550°C. With a local imperfection, the model could support < 0.2% of its room temperature capacity. This shows that a local imperfection has a detrimental effect on a slender member at elevated temperatures and causes it to lose almost all strength.

Up to 400°C, the local imperfection appears to only make a fairly small difference to overall compressive resistance, as maximum deflections are reasonably similar in both models. At 500°C, the model including a local imperfection shows nearly 50% more deflection than without, which indicates it is likely close to failure. This is made clear when the model completely fails due to local imperfection alone at 600°C and above.

In conclusion, local imperfections have little effect on a class 3 RHS section's strength at room temperature and up to 400°C. After 400°C a local imperfection will cause global buckling and failure significantly quicker than with no local imperfection. Because it is likely that all class 3 RHS sections will have a small, local imperfection at the point where brace members transfer load through, it is not safe to use such sections without significant fire protection materials covering the steel. The sudden buckling that the local imperfection caused is far more dangerous than the reasonably linear behaviour the RHS with no local imperfection experienced.

Acknowledgements

I would like to express my deep gratitude to Dr Shanshan Cheng, my project supervisor, for continued guidance, encouragement and useful critiques throughout the course of the project. I would also like to thank all Plymouth University staff for consistent technical support.

References

- Chen, H. (2018). *An Overview of Cold-Formed Steel Structures - An Online Course for Engineers and Architects*. [online] Pdhonline.com. Available at: <https://pdhonline.com/courses/s101/s101.htm>
- Couto, C., Vila Real, P., Lopes, N. and Zhao, B. (2014). Effective width method to account for the local buckling of steel thin plates at elevated temperatures. *Thin-Walled Structures*, 84, pp.134-149.
- Degée, H., Detzel, A. and Kuhlmann, U. (2008). Interaction of global and local buckling in welded RHS compression members. *Journal of Constructional Steel Research*, 64(7-8), pp.755-765.
- ESTEIQ. (2017). *How accurate is FEA?*. [online] Available at: <https://esteq.co.za/2014/10/21/accurate-fea/> [Accessed 2 Dec. 2017].
- Feng, R. and Young, B. (2012). Design of cold-formed stainless steel tubular joints at elevated temperatures. *Engineering Structures*, 35, pp.188-202.
- Kwon, Y. and Seo, E. (2013). Prediction of the compressive strength of welded RHS columns undergoing buckling interaction. *Thin-Walled Structures*, 68, pp.141-155.
- Lawson, R. and Newman, G. (1996). *Structural fire design to EC3 and EC4, and comparison with BS 5950*. Ascot: Steel Construction Institute.
- Ma, J., Chan, T. and Young, B. (2017). Design of cold-formed high strength steel tubular beams. *Engineering Structures*, 151, pp.432-443.
- Ozyurt, E., Wang, Y. and Tan, K. (2014). Elevated temperature resistance of welded tubular joints under axial load in the brace member. *Engineering Structures*, 59, pp.574-586.
- Pointer, J., (2004). "Understanding Accuracy and Discretization Error in an FEA Model," ANSYS 7.1, 2004 Conference, Woodward Governor Company.

Rendall, M. and Rasmussen, K. (2015). Localised geometric imperfection analysis and modelling using the wavelet transform. *Thin-Walled Structures*, 96, pp.202-219.

Rickman, J. (2003). Structural behaviour of cold-formed thin-walled short steel channel columns at elevated temperatures. Part 1: experiments. *Thin-Walled Structures*, 41(6), pp.543-570.

Sadovský, Z., Kriváček, J., Ivančo, V. and Ďuricová, A. (2012). Computational modelling of geometric imperfections and buckling strength of cold-formed steel. *Journal of Constructional Steel Research*, 78, pp.1-7.

Shah, C., (2002). Mesh Discretization Error and Criteria for Accuracy of Finite Element Solutions. Paper presented at the Ansys Users Conference, Pittsburgh, PA

Schafer, B. (2008). Review: The Direct Strength Method of cold-formed steel member design. *Journal of Constructional Steel Research*, 64(7-8), pp.766-778.

Schafer, B. and Peköz, T. (1998). Computational modeling of cold-formed steel: characterizing geometric imperfections and residual stresses. *Journal of Constructional Steel Research*, 47(3), pp.193-210.

Tatasteeleurope.com. (2017). *Structural Hollow Sections | Tata Steel in Europe*. [online] Available at: <https://www.tatasteeleurope.com/en/products-and-services/long/tube/shs/shs> [Accessed 15 Oct. 2017].

Wardenier, J. (2010). *Hollow sections in structural applications*. 2nd ed. Geneva: CIDECT.

Zhao, X., Wilkinson, T. and Hancock, G. (2005). *Cold-formed tubular members and connections*. Oxford: Elsevier, pp.15-33.

Appendices are available as ‘supplementary files’ (please see download area)