

2021

# The development and manufacture of a composite mobility aid for a Paralympic Table Tennis player

Pickup, Ryan

Pickup, R. (2021) 'The development and manufacture of a composite mobility aid for a Paralympic Table Tennis player', *The Plymouth Student Scientist*, 14(1), pp. 341-404.

<http://hdl.handle.net/10026.1/17328>

---

The Plymouth Student Scientist

University of Plymouth

---

*All content in PEARL is protected by copyright law. Author manuscripts are made available in accordance with publisher policies. Please cite only the published version using the details provided on the item record or document. In the absence of an open licence (e.g. Creative Commons), permissions for further reuse of content should be sought from the publisher or author.*

# **The development and manufacture of a composite mobility aid for a Paralympic Table Tennis player**

Ryan Pickup

*Project Advisor: [Professor John Summerscales](#), School of Engineering, Computing and Mathematics, University of Plymouth, Drake Circus, Plymouth, PL4 8AA*

## **Abstract**

Table Tennis is the third largest Paralympic Sport with competitors competing from over a hundred countries. David Wetherill is a three-time Paralympian who will be competing in the Tokyo 2020 Paralympic Games and currently competes with a standard crutch. This paper is based around improving the crutch for Mr Wetherill using the research to advise on how crutches can be improved for long term users, providing them a better quality of life. For Mr Wetherill the goals were to create a composite mobility aid that met all the requirements laid out by the athlete and using current research in different mobility aids, advancements in materials and manufacture techniques. Full CAD models were created using both Solidworks and ANSYS software's showing the smallest failure of 875N is considered satisfactory. With results validated using first principal calculations and coupon testing. A final design was created and will be manufacture in the fall of 2020, to be used by Mr Wetherill at the Tokyo 2020 Paralympic Games. Applying the current research into crutches and understanding current issues long term users face, design changes have been advised using the advancements in manufacture techniques or materials, for example 3D printing and composite materials to improve the quality of life of long-term crutch users.

**Keywords:** composite mobility aid, Multiple Epiphyseal Dysplasia, athlete, Paralympic Table Tennis, David Wetherill, Paralympian, development, CAD.

## Introduction

Sir Ludwig Guttmann in 1948 organised the first competition for disabled athletes for members of the Stoke Mandeville Hospital to improve the psychological well-being of his patients, this coincided with the 1948 Olympic Games in London. The first official Paralympic Games were held in Rome where 23 countries participated. At the Paralympics 10<sup>th</sup> anniversary in Atlanta 1996 the event had grown to 104 countries. (Tepper, Kroner and Sonnenschein, 2001). Table Tennis was played at the first Paralympic Games by 35 athletes, it is now the third largest Paralympic Sport. (National Paralympic Heritage Trust, 2019).



**Figure 1** - David Wetherill (photograph taken by Ryan Pickup) is a class 6 athlete which is the category for the most impaired athletes that stand. It is defined by the International Table Tennis Federation as athletes that “have severe impairments in both their arms and legs due to incomplete spinal-cord injuries, neurological conditions which affect both or one side of the body, amputations or congenital conditions. Some players even handle the racket with their mouths.” (International Paralympic Committee, 2019)

David Wetherill (The Athlete) (Figure 1) is a Paralympic table tennis player who has competed in three Paralympic Games (Beijing 2008, London 2012 and Rio 2016), ranked 4<sup>th</sup> in the world as of December 2019 (Ipttc.org, 2019). David Wetherill was born with the dominant type of Multiple Epiphyseal Dysplasia a disorder of cartilage and bone development which mainly affects the ends of long bones (arms and legs), it occurs due to mutations in specific genes: COMP, COL9A1, COL9A2, COL9A3 or MATN3 which is fundamental in the formation of cartilage and bone. This mutation caused the formation of abnormal cartilage which prevents the development of bone as a child this is a very rare disorder only seen in 1 in 10,000 births. (Genetics Home Reference, 2019)

Over the last 11 years of playing there has been very little adaptation in the athlete's current crutch to improve its use as an aid to support during competition. But with no rules currently for crutch design innovative design solutions can be considered.

## **Aims and Objectives**

### **Aims**

The aim of this research is to develop and manufacture a custom composite mobility aid, for a Paralympic Table Tennis Player to use at the Tokyo 2020 Paralympic Games (postponed to 2021 due to COVID-19), which is specifically designed to assist the athlete while playing Table Tennis.

### **Objectives**

1. Evaluate and analyse the current availabilities and future developments of mobility aids for people with injuries or disabilities.
2. Understand the specific requirements for the athlete to enable the creation of a solution.
3. Measure the force on the current mobility aid by the athlete during playing.
4. Use hand calculations to understand the bending of the crutch and use as a validation tool for the experimental data.
5. Construct a Finite Element Analysis (FEA) of current mobility aid using data gathered from the first principle calculations and coupon testing, which will be used as a validation tool when creating the FEA of the final design.
6. Define multiple designs for the new mobility aid and refine down to one preferred solution.
7. Construct the final design for the mobility aid using multiple manufacturing techniques.
8. Test high stressed components of the mobility aid using material testing machines and validate its ability to meet the requirements by comparing it to experimental data, hand calculations and FEA.

## **Literature Review**

A mobility aid is defined as a piece of equipment which aids in the movement from place to place if you suffer from a disability or an injury. (Medline Plus, 2019) The current possible solutions available that aid people with a range of injuries and disabilities are canes, crutches, walkers, and wheelchairs. (Leonard, 2019) With more advanced exoskeletons (Zhang et al., 2011) or spring-loaded crutches (Contreras-Vidal et al., 2016) focusing on allowing people with long term injuries to live as normal life a possible or speed up recovery time.

In the sporting world for athletes composite running blades, are becoming common at the Paralympics, with the use of carbon fibre blades which are designed to their exact size and running style. (Running blades rely on composites, 2012) In an ideal world, a blade would transfer the energy perfectly, following Hookes Law, but this is never acheived with a range of efficiencies are seen depending on the design of the blade. (Scholz et al., 2011) the different possible prosthetic foot designs available each with varying efficiencies: (a) Cheetah (Össur) , (b) Flex-Run (Össur), (c) Flex-Sprint (Össur), (d) C-Sprint (Otto Bock), (e) Sprinter (Otto Bock) a range of 31-95% efficiency can be seen over these 5 designs all from one manufacturer. These

different designs are required because of users having varying injuries as well as varying performance needs. (Scholz et al., 2011) There is also a range of materials used depending on the design and the use of the blade, with glass or carbon fibre being the two main choices with their ability to increase stiffness, allowing a quicker return to original shape and a higher efficiency. (Noroozi et al., 2012)

Potter and Wallace (Potter and Wallace, 1990) say the modern crutch allows better transfer of weight to the arms and provides more relief than traditional wooden crutches or walking sticks. Also being used to improve the balance, stability, safety, and walking performance of the user. (Freddolini et al., 2018) There are only a few areas where crutches have currently been studied with the focus being on the handgrip and the energy consumption of using crutches. With the main emphasis of improvement being in the hand grip where an increase in width can show a 12% reduction in the forces experienced in the users palm. . (Sala et al., 1998) A reduction in weight is also known to significantly reduce the fatigue experienced by anybody using crutches (Wu et al., 2011). One solution is composite crutches that are seen to be 60% lighter as well as 20% stronger and 90% quieter by making them out of a single custom tube also allows for reduced stress concentrations leading to a longer lasting product. (Degaspari, 2001)

Despite all research that has occurred there has been no viable solution created for athletes who use crutches in sport, especially with regards to variation of use in the different sports. Due to a lack of development for long term crutch users medical issues like 'crutch palsy' (Raikin and Froimson, 1997) are becoming serious issues especially with no mass producible solution.

## **Research Methodology**

### **Current Crutch Analysis**

#### *Requirements from Athlete*

A full specification was created following the Potter's checklist, to understand the requirements for the project. During sessions to assess the athlete, several potential areas of improvement were identified. (a) helping the athlete gain confidence during service that the crutch will remain on the athlete's arm, (b) increasing the surface area of the foot at the angle in which the crutch is going to be used proving a more stable platform, (c) reducing the weight of the crutch assembly.

Prior to deciding the design for the crutch several areas of research were undertaken to analyse current crutches available and specific competition usage. During interviews with the athlete, the crutch was broken down into four main components: (i) the Arm Support (Cuff), (ii) the Hand Grip, (iii) the Stem and (iv) The Foot. These were identified as the areas which had to be designed specifically for the athlete (Table 2).

**Table 1:** Describing the requirements for each component of the crutch as set out by the athlete.

| Section of the Crutch          | Requirements  |
|--------------------------------|---|
| <b>The Arm Support (Cuff):</b> | <ul style="list-style-type: none"> <li>- Needs high stiffness</li> <li>- No need for the opening in the arm support but there needs to be enough room to accommodate the elbow joint during service, therefore, either the circle needs to be big enough or a flexible strap system must be used.</li> <li>- The current top experiences small movement in the z axis which should be avoided.</li> <li>- A high need to consider the elbow joint and have movement in the y axis of over 90° of movement.</li> </ul> |
| <b>The Hand grip:</b>          | <ul style="list-style-type: none"> <li>- Considered by the athlete as “Not what I have trouble with”.</li> <li>- Consider a wider grip.</li> <li>- Try and keep the shape despite changing the design to integrate with the new crutch design.</li> </ul>   |
| <b>The Stem:</b>               | <ul style="list-style-type: none"> <li>- Requires high stiffness.</li> <li>- Durable.</li> <li>- Ability to use in all environments.</li> </ul>   |
| <b>The Foot</b>                | <ul style="list-style-type: none"> <li>- Needs to have as large a surface area as practical and to try and replicate a human foot.</li> <li>- A suitable material will be selected for the foot and needs to have a suitable level of friction for all possible playing surfaces and not react differently in the presence of moisture.</li> <li>- The foot grip needs to have the ability to be easily changed once the material was worn past its optimal performance.</li> </ul>                                   |

*Previous composite Crutch Analysis*

During the design development phase, the athlete discussed a previous crutch which was made for him by University of Plymouth MATS348 students before the 2008 Beijing Olympics. To understand why this crutch wasn't used (Figure 2 & 3) a comprehensive review of the previous composite crutch was completed against the current crutch (results in Table 3).



**Figure 2:** The overall measurements of the crutch were not exact to the athlete's specification, meaning it was too tall, causing the crutch arm support to press into the athletes under arm, making it uncomfortable for use, these forces can also cause long term damage like crutch palsy which for anyone who uses crutches every day is not acceptable.



**Figure 3:** Compared to the current crutch, majority of the force is distributed through the forearm but due to the composite crutches forearm support being just an elastic strap all forces are distributed to the hand and underarm which is not practical.




**Table 2:** All previous composite analysis with will be used to help with the development process of the final crutch, with the aim to overcome all the issues discovered during this analysis and prevent any repetition of avoidable issues.

| <b>Composite Crutch (Previous Design)</b>  |  |
|--|--|
| <b>Positives</b>   | <b>Negatives</b>   |
| <p>Elastic Strap increase control and reassurance the crutch will remain attached</p> <p>Hand Grip is very comfortable to use and distributes the load more evenly than the current crutch</p> <p>Material would not become slippery because of sweat during use.</p> <p>Elastic strap would function well during use as it absorbs sweat but would still be able to complete its purpose.</p> | <p>The strap only supports in a single plane and no force is able to be transferred through the forearm. (Whereas all 6 degrees of freedom were considered during initial testing)</p> <p>The back section provides no support during the twisting movement, causing the athlete to push harder into the hand grip.</p> <p>Material absorbs sweat which isn't hygienic.</p> <p>Crutch was heavier due to the tubing being too large.</p> |





*Ferrules Analysis*

To analyse the ferrule section a variety of ferrules were purchased and then analysed with the athlete to decide benefits and qualities the foot required. (Table 4)

**Table 3:** Ferrules Analysis Table –these results show that that the material of the foot performs better the lower the material stiffness is, this allows for better grip in all environments, but may degrade over time but due to this being used in a high-performance environment this is acceptable.

| <b>Ferrule Number</b>  | <b>Picture</b>   | <b>Positives</b>  | <b>Negatives</b>   |
|--|--|---|--|
| <p><b>1</b></p> <p>Maximum Contact Area = 616 mm<sup>2</sup></p> <p>Weight = 0.024kg</p> |  <p><b>Figure 4</b></p> | <p>Very lightweight</p> <p>Good grip when used vertically</p> | <p>Small contact surface area</p> <p>Small push off area</p> <p>Low grip at angle of use</p> |



|  |  |   |  |
|--|--|---|--|
| <p><b>2</b><br/>Maximum Contact Area = 1520 mm<sup>2</sup><br/><br/>Weight = 0.076kg</p> |  <p style="text-align: center;"><b>Figure 5</b></p>   | <p>At angle of use provides good grip</p> <p>Stiff material which leads to a longer lasting ferrule</p> | <p>Grip reduction when angle passes 45 Degrees</p> <p>Degrades very quickly on edges</p> <p>Very heavy</p> |
| <p><b>3</b><br/>Maximum Contact Area = 4907 mm<sup>2</sup><br/><br/>Weight = 0.140kg</p> |  <p style="text-align: center;"><b>Figure 6</b></p>   | <p>Large surface area</p> <p>Very flexible and capable at working over varying angles</p>               | <p>Very clunky</p> <p>Very heavy</p> <p>Not dynamic</p> <p>Wouldn't work at the large angles of use</p>    |
| <p><b>4</b><br/>Maximum Contact Area = 1590 mm<sup>2</sup><br/><br/>Weight = 0.064kg</p> |  <p style="text-align: center;"><b>Figure 7</b></p>  | <p>Stiffer material making it longer lasting</p> <p>Good grip when used vertically</p>                  | <p>Heavier</p> <p>Grip design not suitable at angle of use</p> <p>Causes sliding during use</p>            |
| <p><b>5</b><br/>Maximum Contact Area = 1257 mm<sup>2</sup><br/><br/>Weight = 0.056kg</p> |  <p style="text-align: center;"><b>Figure 8</b></p> | <p>Lighter</p> <p>Better grip during use</p> <p>Very flexible creating a larger surface area</p>        | <p>Degrades very quickly In hot environment degrades even quicker</p> <p>Couldn't be used outside</p>      |

|  |   |   |  |
|--|---|---|--|
| <p><b>6</b><br/>Maximum Contact Area = 830 mm<sup>2</sup><br/><br/>Weight = 0.022kg</p>  |  <p style="text-align: center;"><b>Figure 9</b></p>  | <p>Very light weight<br/><br/>Very practical in wet conditions</p>                  | <p>Not practical for usage during playing<br/><br/>Gripping bobbles degrade quickly and don't provide extra grip</p> |
| <p><b>7</b><br/>Maximum Contact Area = 1662 mm<sup>2</sup><br/><br/>Weight = 0.082kg</p> |  <p style="text-align: center;"><b>Figure 10</b></p> | <p>Rounded end foot allows for large contact surface area<br/><br/>Very durable</p> | <p>Angles of use not suitable for the bend on ferrule.<br/><br/>Very bulky<br/><br/>Kept falling off crutch end</p>  |

The testing required, and results of this table have shown that there is a clear set of objectives in which the foot must follow to achieve the performance required by the athlete for their best performance. The least performing ferrules were 3 & 7. Another aim of the final design needs to improve surface area at the angle in which the crutch is going to be used, all the current ferrules are designed to be used as close to vertical but that differs for the athlete.

### Testing of Athletes Current Crutch

#### *Ethical Form and Risk Assessment*

- Following University procedure, the following paperwork was completed:
- Ethical approval form was signed by the athlete, agreeing that they fully understand their rights and gave permission for the use of their personal information in this paper.
- A full Risk and COSHH assessment was made to ensure anyone who completed lab work had been through all Health & Safety training.
- All manufacture and testing was completed following all standard procedures and a full risk assessment was adhered too.

*Initial Fundamental Experiment*



**Figure 11:-** During initial observation of the athlete playing, the athletes movement could be broken down into 3 basic positions, these were Forehand position, Backhand position and Push off position. The Forehand Position was deemed to have the crutch positioned to the side of the body, the Backhand Position was deemed to have the crutch in front of the body and the push off position was deemed to be the athlete in the side step position with crutch out to the side.

For initial fundamental testing a set of scales was used with a camera to measure the vertical force which is experienced when the athlete assumed one of the three positions (Figure 11). For the Forehand Position the highest possible value of 149N, the Backhand Position had the highest possible force of 158N and the Push off Position had the highest possible force 328N. This shows that the push off movement is the most extreme environment the crutch experiences. This experiment along with the simple bending beam calculations show what forces the crutch currently experiences.

*Strain Testing*

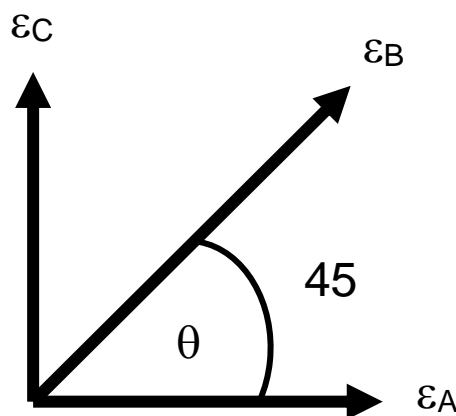
Developing from the requirements stated by the athlete, a strain gauge was attached to the athletes current crutch just below the handle section (Figure 12), this was

highlighted as one of the major points in which the largest forces could be experienced and seen as a major stress point.



**Figure 12:** The attachment of the strain gauge to the current crutch. The process in which the strain gauge was attached involved cleaning the crutch by removing all rust and paint so the gauge could be attached directly to the aluminium tube.

This was derived by eye, focusing on the area where bending has currently occurred. The gauge consisted of 3 individual gauges one which occurred down the y-axis of the crutch, another which wrapped around the crutch in the x-axis to measure torsion/twist and finally the strain gauge at 45 degrees to the other gauges to allow all three dimensions to be measured when the crutch is used at an angle. Seen in Figure 13.



**Figure 13:** The directions in which each of the strains were measured. When data was analysed the first two values and the last two values were removed as this could have occurred when the athlete wasn't performing the shot.

The values below are taken from the collected data during the practical with each different possible position of use of the crutch, the data was recorded in Table 5. The maximum value which was used in all equations below was taken as either the largest positive or the largest negative number, this was so that the force values produced were the largest possible forces experienced by the crutch.

**Table 4:** Results table of strain values from crutch experiment which were recorded in  $\mu\epsilon$ . The largest values were chosen from the results this was so that the force values produced were the largest possible forces experienced by the crutch.

| Movement<br>(units) | $\epsilon_A = \epsilon_x$<br>- | $\epsilon_B$<br>-          | $\epsilon_C = \epsilon_y$<br>- |
|---------------------|--------------------------------|----------------------------|--------------------------------|
| Backhand Topspin    | 0.000059 (11.9) (20.3%)        | 0.0000658 (14.4) (21.9%)   | 0.000227 (49.3) (21.8%)        |
| Backhand Touch      | 0.000066 (30.8) (46.5%)        | 0.000074 (47.1) (63.4%)    | 0.000254 (171) (66.9%)         |
| Forehand Topspin    | 0.0000186 (16.7) (33.7%)       | -0.0000128 (22.4) (-39.5%) | -0.000097 (54) (25.4%)         |
| Forehand Touch      | 0.000064 (29.6) (46.3%)        | -0.0000696 (33.8) (-48.6%) | -0.000221 (104) (-47.1%)       |
| Forehand Push-Off   | 0.0000186 (46.0) (247%)        | -0.0000128 (61.1) (-476%)  | -0.000097 (222) (-229%)        |
| Push-off Attempt 1  | 0.0000568 (75.5) (133%)        | -0.0000564 (88.4) (-157%)  | -0.000203 (278) (-137%)        |
| Push-off Attempt 2  | 0.0000768 (86.1) (112%)        | -0.0000726 (95.7) (-132%)  | -0.000270 (352) (-131%)        |

For all positions and movements that were identified during visual analysis were recreated during the strain gauge testing and the maximum values collected from the testing have been put through a set of equations and the values can be seen in Table 6.

**Table 5:** Results table showing stress and maximum shear stress that could be expected to occur in the different movements the athlete undertakes. For full calculation breakdown please see

| Movement<br>(Units) | $\epsilon_A = \epsilon_x$<br>MAX<br>- | $\epsilon_B$<br>MAX<br>- | $\epsilon_C = \epsilon_y$<br>Max<br>- | $\sigma^1$<br>MPa | $\sigma^2$<br>MPa | $\tau_{MAX}$<br>MPa |
|---------------------|---------------------------------------|--------------------------|---------------------------------------|-------------------|-------------------|---------------------|
| Backhand Topspin    | 0.00008                               | 0.000087                 | 0.000294                              | 15.5              | -3.94             | 8.6                 |
| Backhand Touch      | 0.000118                              | 0.000173                 | 0.000651                              | 29.8              | -8.54             | 16.8                |
| Forehand Topspin    | 0.000073                              | -0.000104                | -0.000303                             | 0.146             | -2.49             | 1.19                |
| Forehand Touch      | 0.000116                              | -0.00013                 | -0.000437                             | 0.833             | -3.56             | 1.93                |
| Forehand Push-Off   | 0.000182                              | -0.000215                | -0.000757                             | 1.97              | -8.5              | 4.59                |
| Push Off Attempt 1  | 0.000211                              | -0.000232                | -0.000786                             | 1.57              | -6.27             | 3.44                |
| Push Off Attempt 2  | 0.000206                              | -0.000223                | -0.000799                             | 2.19              | -7.87             | 4.43                |

This data highlights that the Backhand Touch experiences the largest principal stresses due to it having higher average forces in all three planes with the forces all being experienced in the positive direction. The Push-off was expected to have the highest possible stress value but some are in the negative plane showing that at this point the crutch is experiencing compression. All values are shown to comply with the expressions, giving a value for  $\sigma_{Ult}$  of 124 MPa, therefore the material is validated with a  $\sigma_{Ult}$  of 665 MPa as suitable for the purpose.

### Research from participants who use crutches in everyday life

During research about crutches and talking to people who have used crutches for a long period of time, one of the most notable was someone who had been using crutches for the last 4 years due to a knee injury, over this time multiple different styles of crutches had been tested with results in Table 7.

**Table 6:** Crutch analysis from interview – these results gave a good perspective of what life is like for someone who spends a lot of time using a crutch.

| <b>Crutch Type</b>                   | <b>Positives</b>  | <b>Negatives</b>  | <b>Improvements</b>  |
|--------------------------------------|---|---|--|
| <b>Standard Crutch</b>               | <ul style="list-style-type: none"> <li>- Helped relieve pressure from injured knee</li> <li>- Correct height for maximum use</li> </ul>         | <ul style="list-style-type: none"> <li>- Due to long use pain developed in shoulder (Crutch Palsy)</li> </ul>   | <ul style="list-style-type: none"> <li>- Ferrule design could be improved by allowing more compression (spring loaded)</li> <li>- Remove holes as crutch failed over time</li> </ul> |
| <b>Forearm Crutch</b>                | <ul style="list-style-type: none"> <li>- Force transferred through forearm removing pain in shoulder</li> </ul>                                 | <ul style="list-style-type: none"> <li>- Single arm strap allowed too much lateral movement</li> <li>- Flimsy hand grip preventing a secure grip</li> </ul> | <ul style="list-style-type: none"> <li>- Improve quality of overall crutch with sturdier design</li> </ul>   |
| <b>Standard Crutch (Wide Handle)</b> | <ul style="list-style-type: none"> <li>- Wide handle was far more comfortable for use</li> <li>- Less force is felt through the hand</li> </ul> | <ul style="list-style-type: none"> <li>- Arm support (cuff) was too small and very uncomfortable</li> </ul>   | <ul style="list-style-type: none"> <li>- Custom arm support cuff to have variable diameter</li> </ul>  |

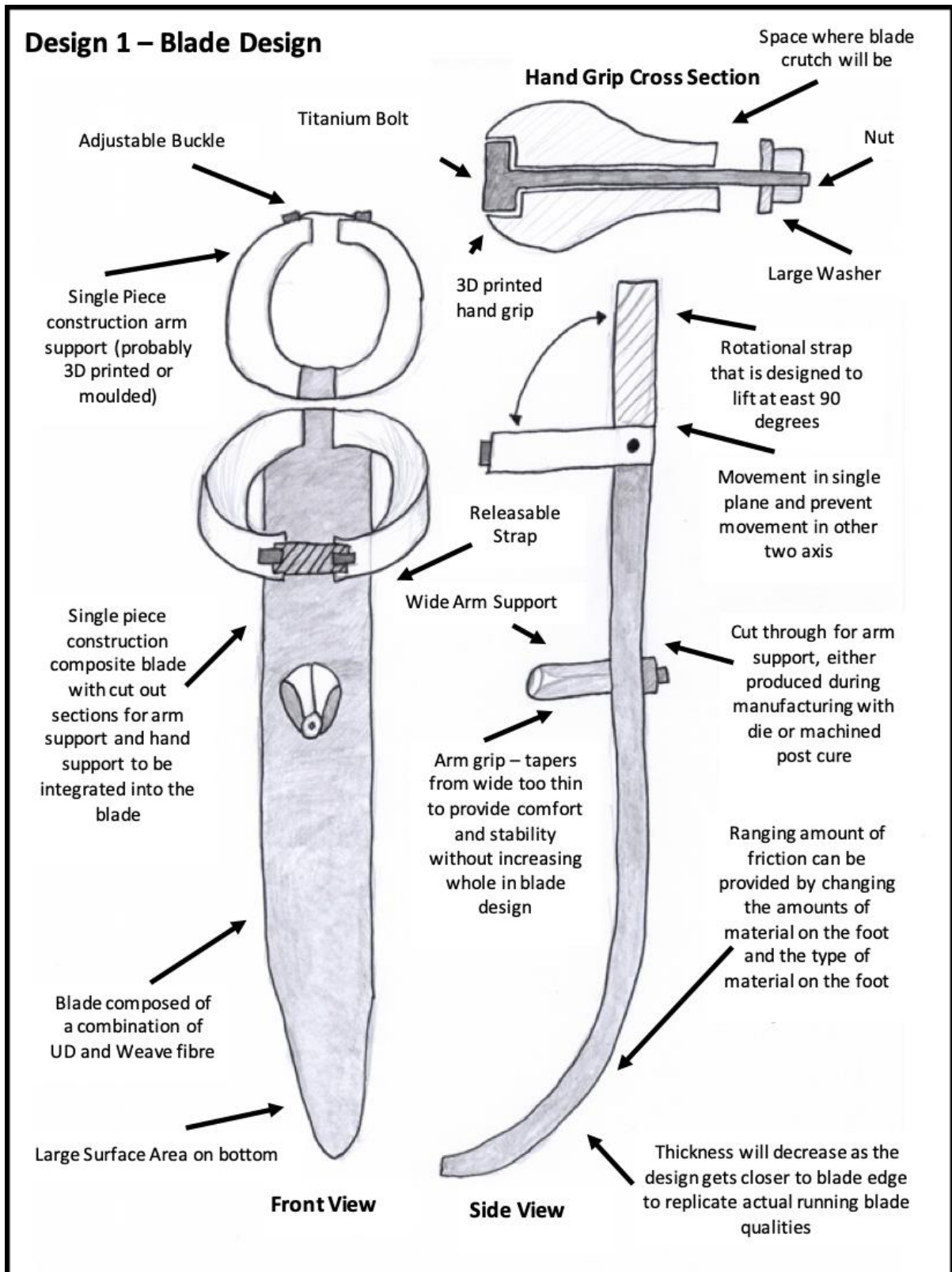
It shows that the current design is ideal for short term use but there is no viable solution for people who use crutches for long term or sport, there have been some advancements but none have really analysed what the user needs.

## Design Development

### Design Ideas

After some research (as seen in the literature review) into the current developments of crutches, a selection of designs were created (Figures 16 – 24) and they were analysed in the decision matrix (Table 8)

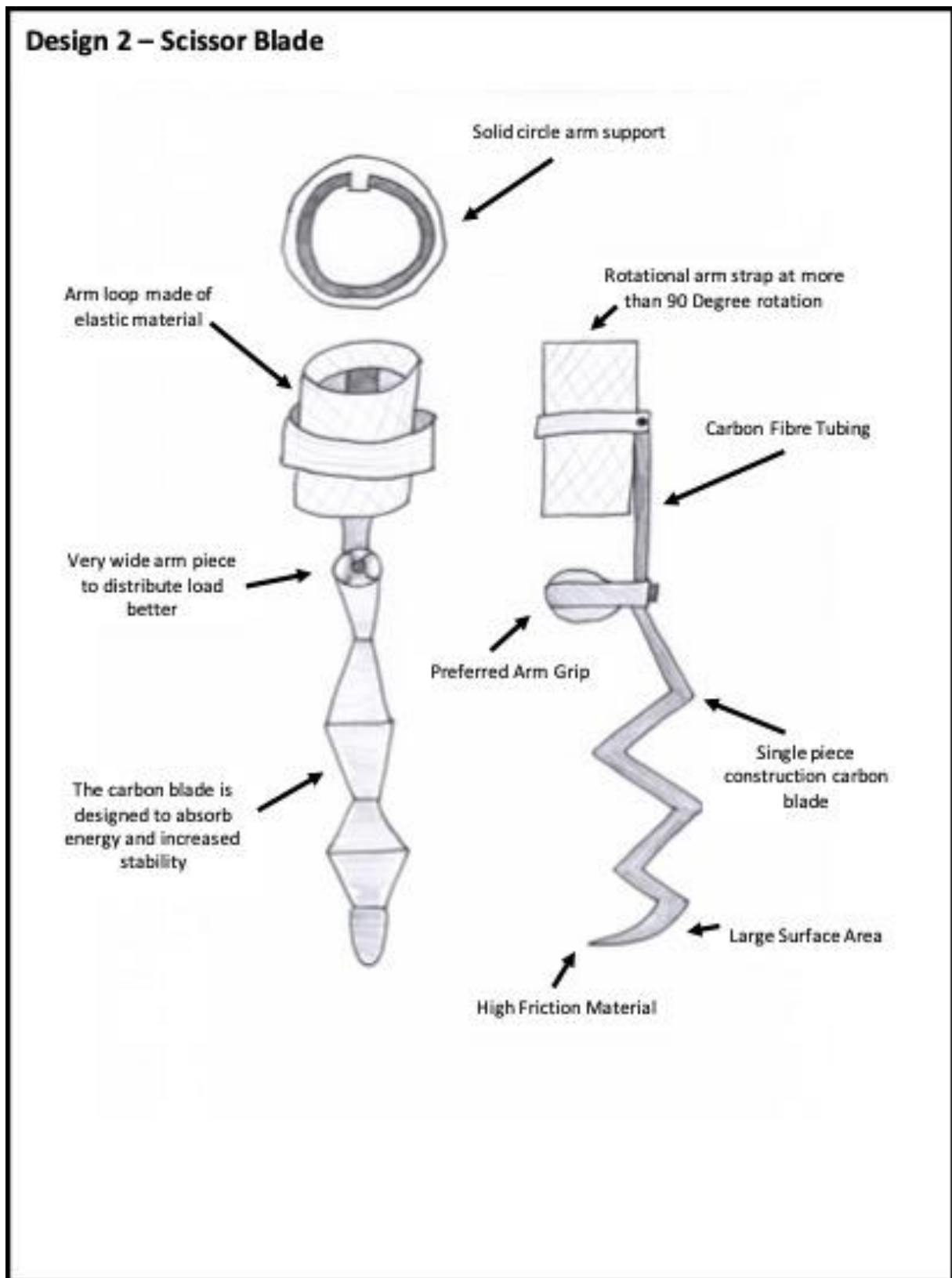
Blade Design



**Figure 14:** Shows the Single Piece Constructed Composite Blade design. With Adjustable arm piece and interchangeable hand grip design allowing easy adjustment or development.

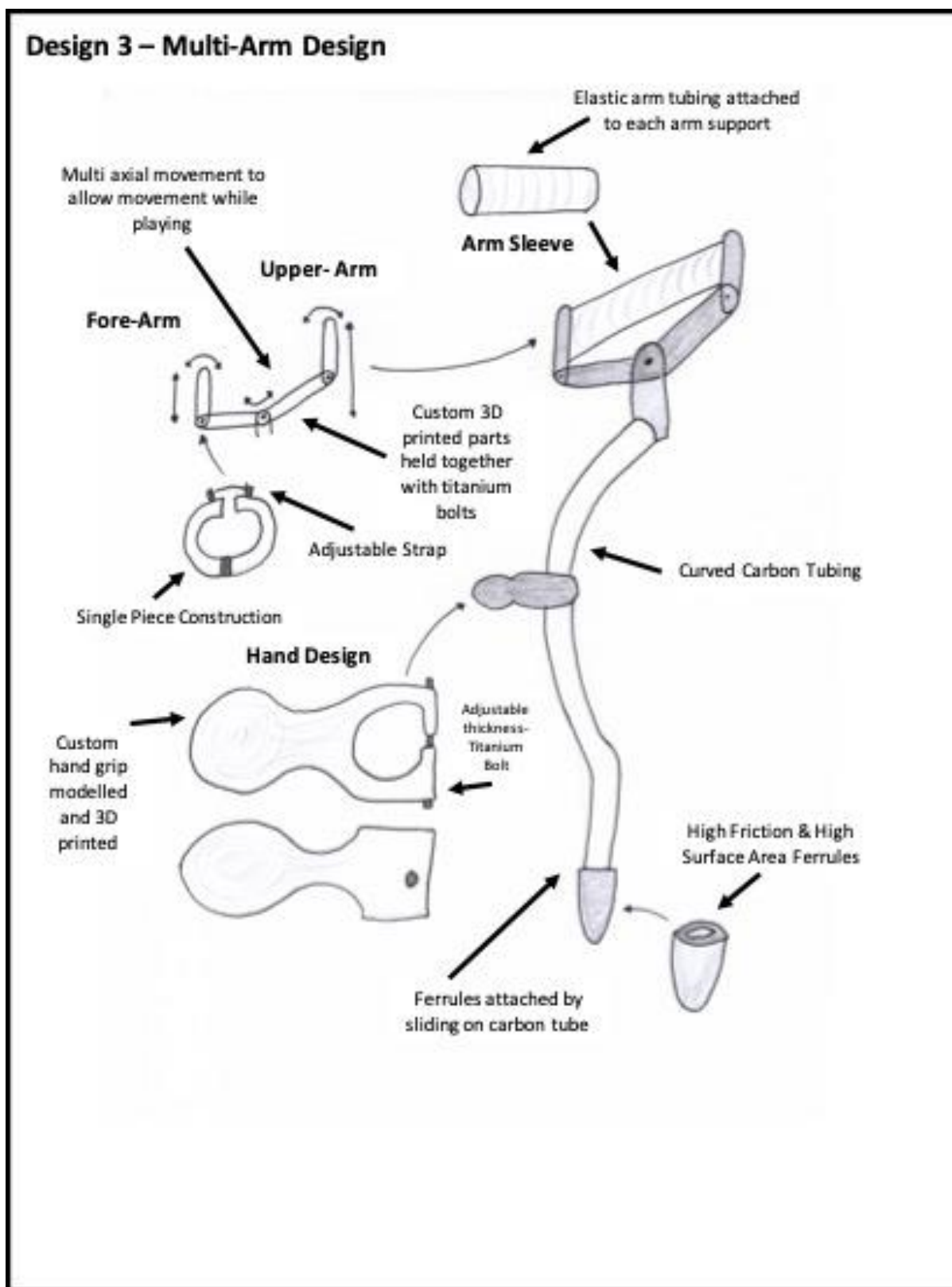


Scissor Blade Design



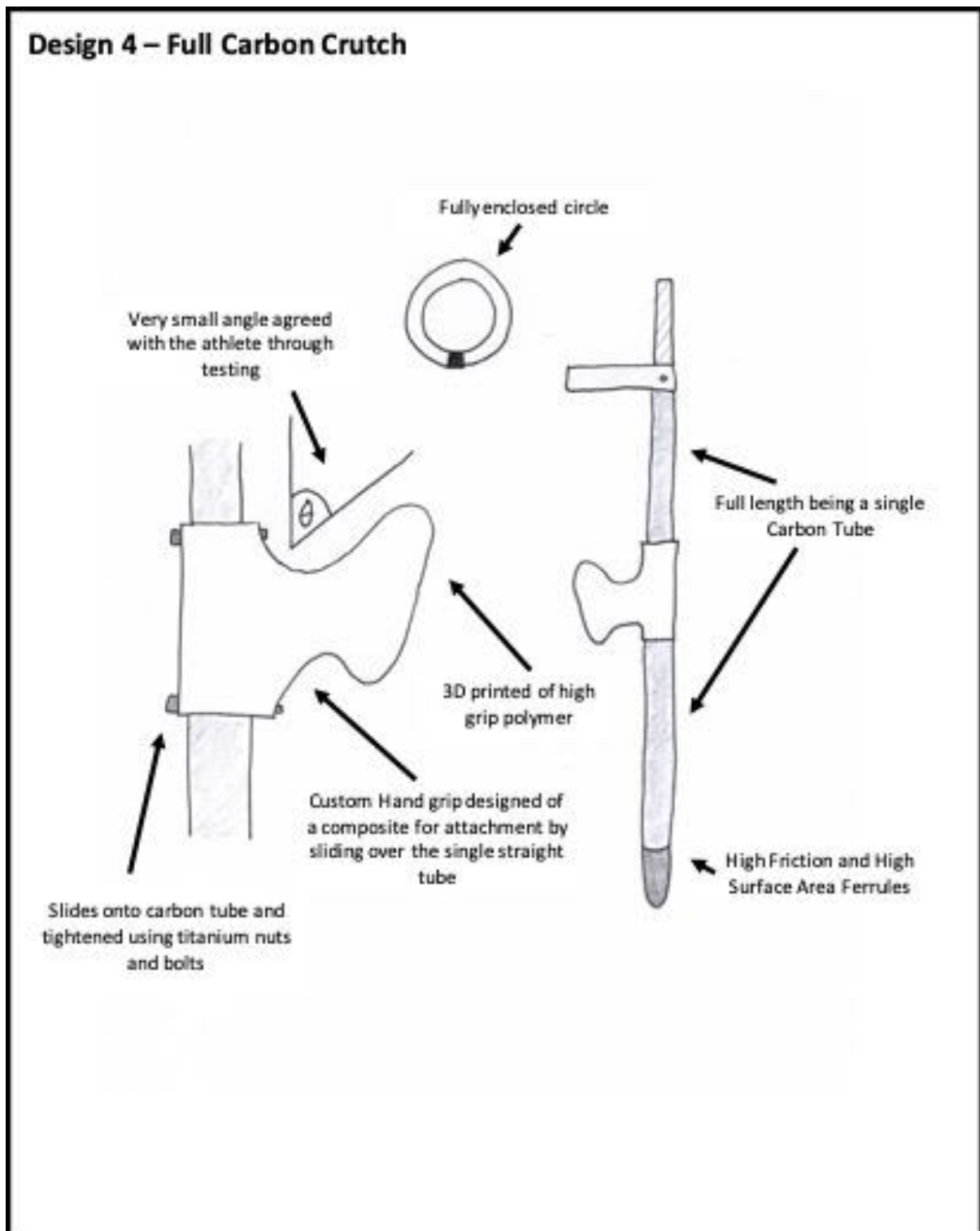
**Figure 15:** Shows a composite blade in the form of multiple leaf springs in a scissor layout. With large arm loop (cuff) and wide handle to allow for more control and support over the whole range of the arm.

Multi-Arm Design



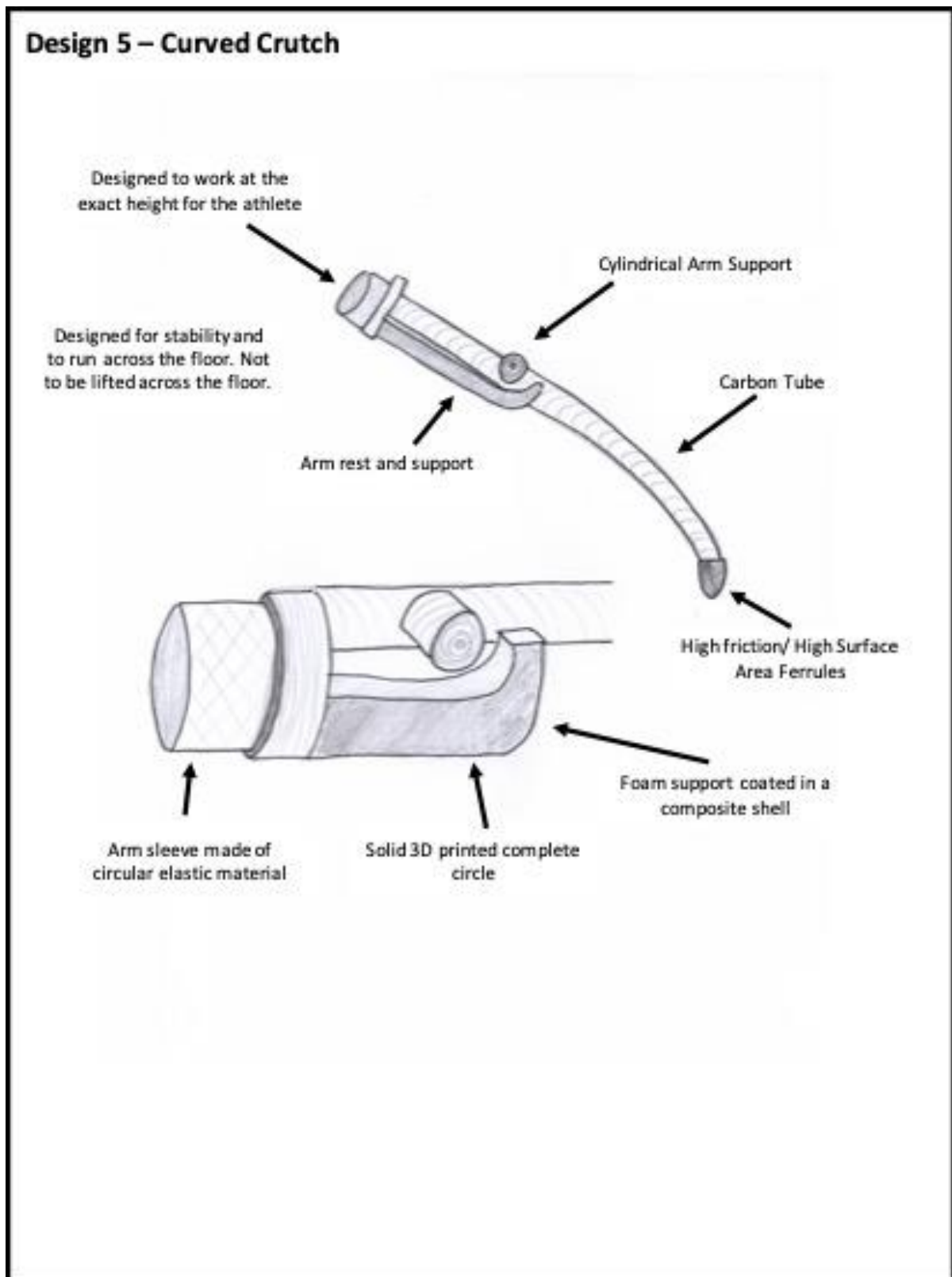
**Figure 16:** Shows a curved composite tube. Wrap around hand grip design with ergonomic shaping and two part arm support (cuff) with multiple moving pivot points and arm sleeve.

Full Carbon Design



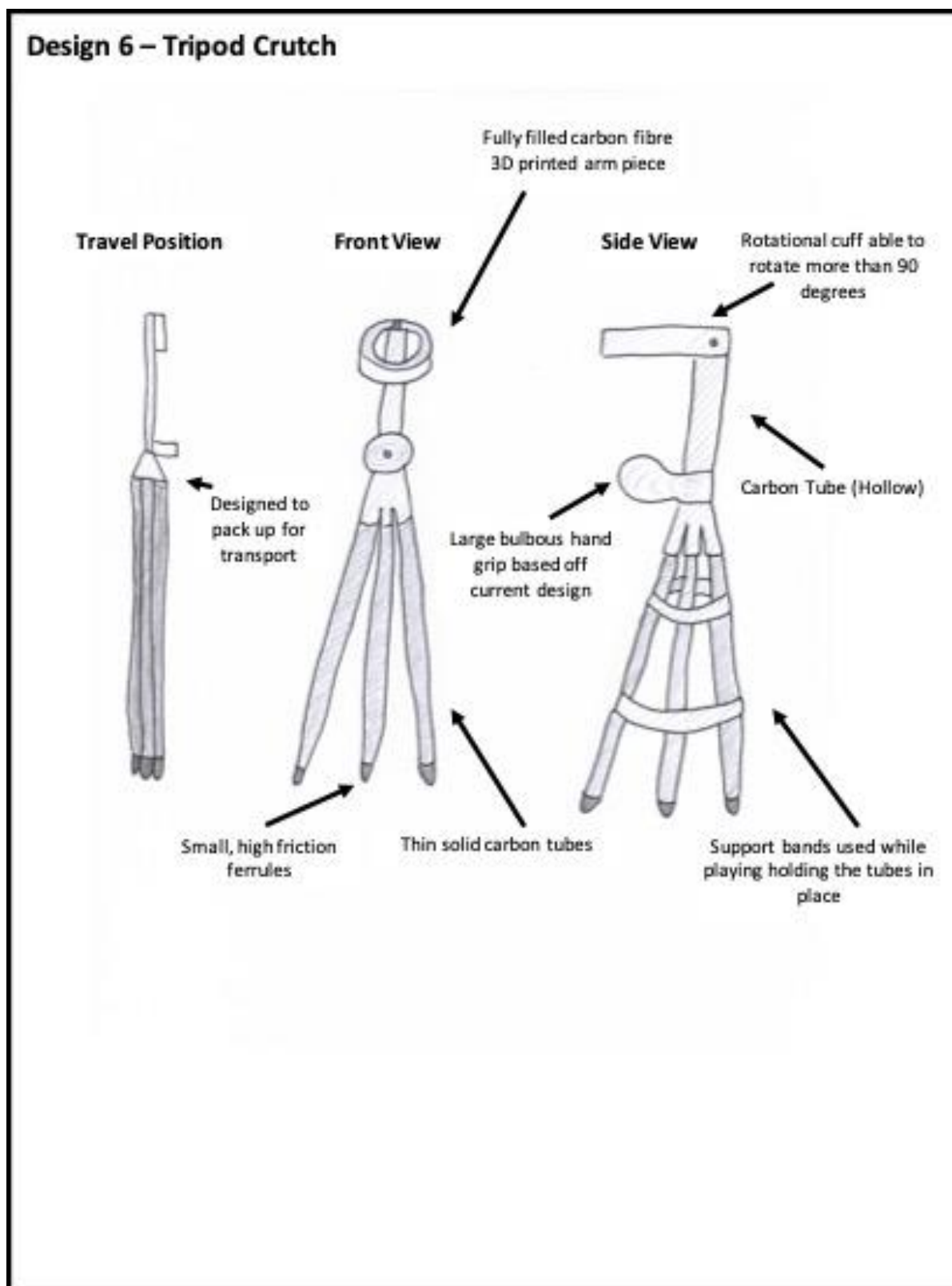
**Figure 17:** Shows a single straight composite tube. With hand grip integrated into a sleeve design which slides over tubing and arm support (cuff) being fully enclosed circular design.

Curved Crutch



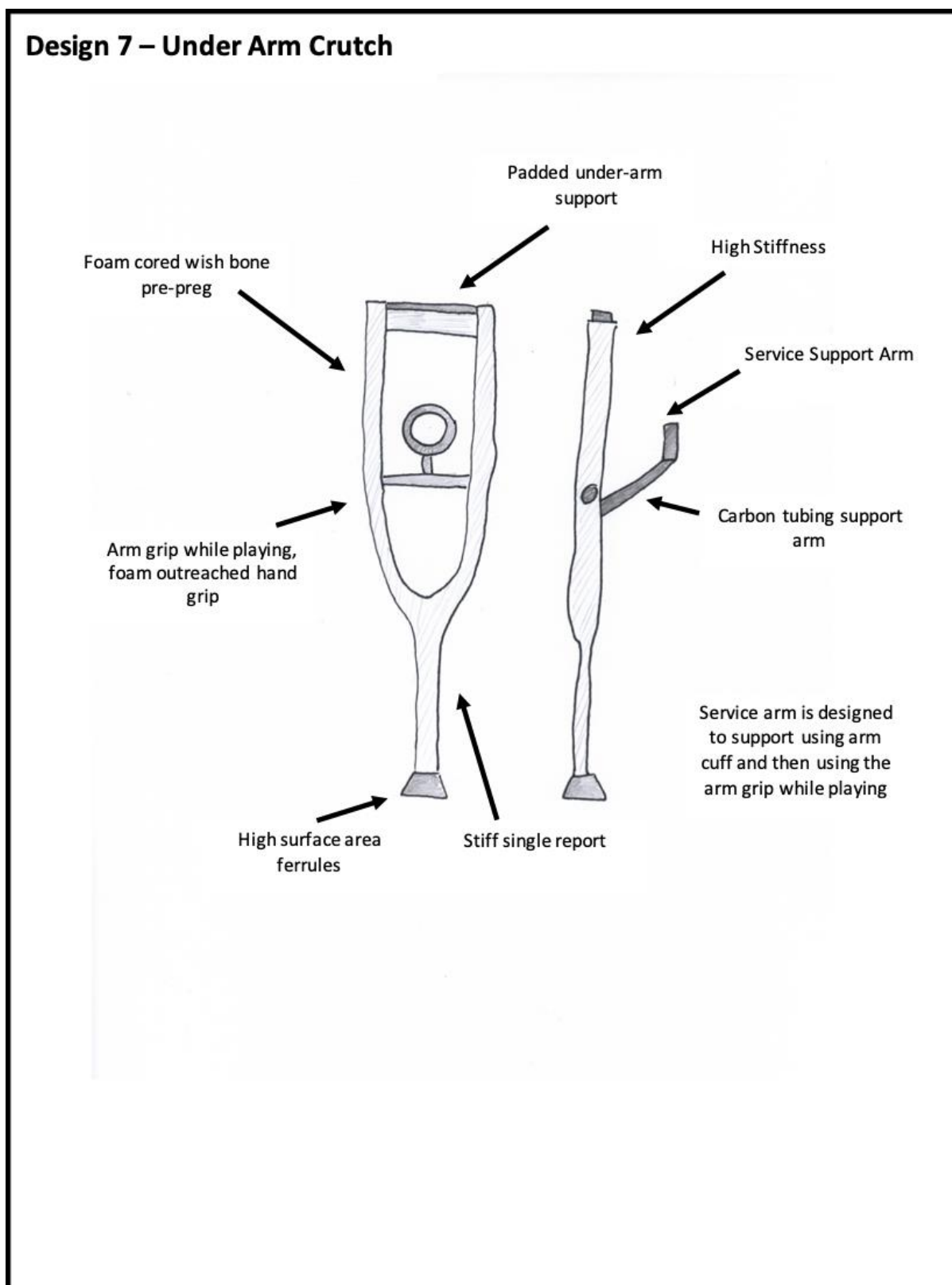
**Figure 18:** Shows a curved composite tube which allows for the athletes arm to remain at same angle but increase crutches contact area on the ground. Arm support (cuff) wraps around the arm fully and the hand grip has integrated with arm rest.

Tripod Crutch



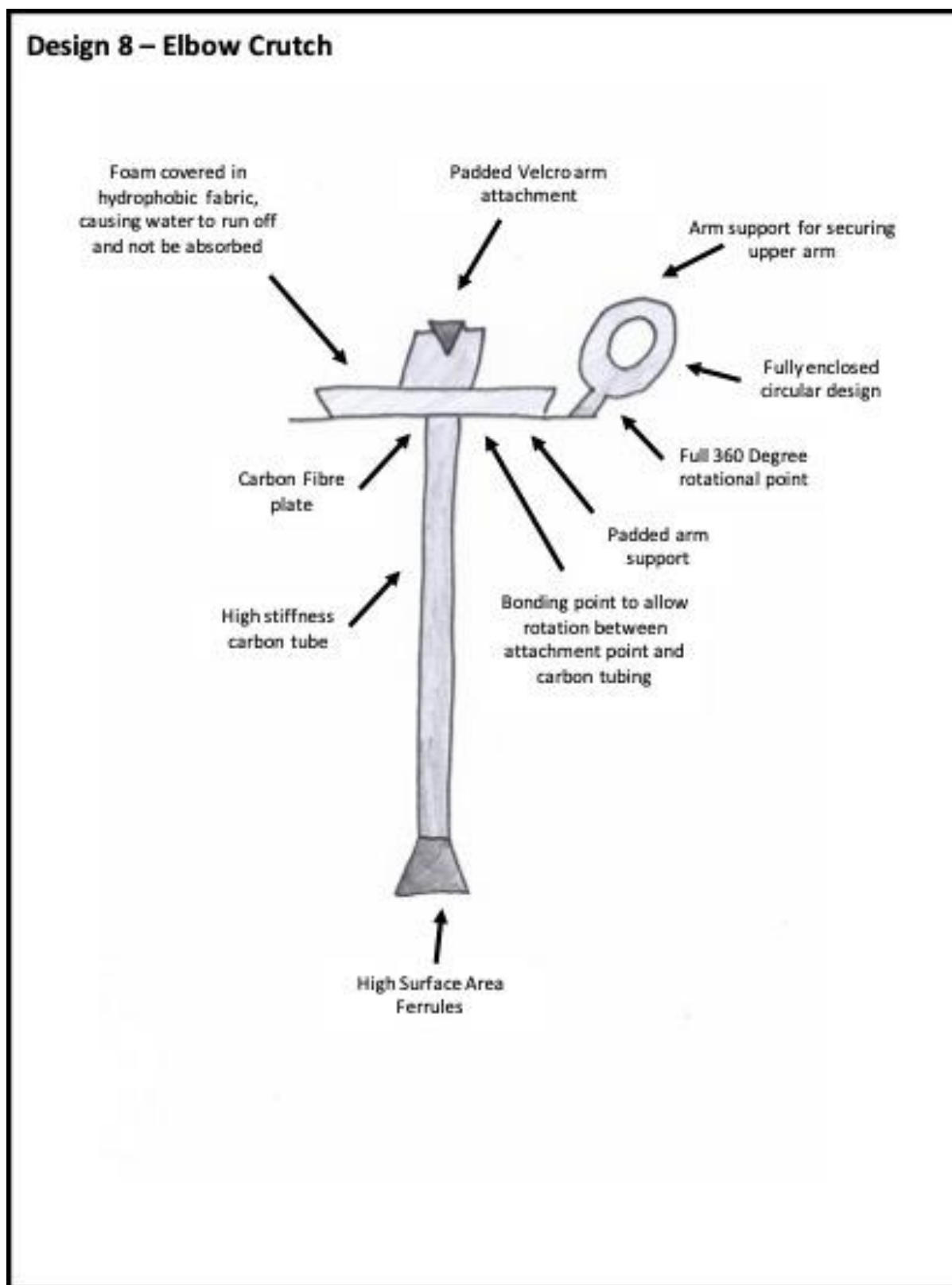
**Figure 19:** Shows the multiple composite tubes that are held together using elastic bands, can be folded away for travel. Hand Grip has large bulbous design to increase contact area for force load. Solid arm support (cuff) that wraps around the arm completely.

Under-Arm Crutch



**Figure 20:** Shows a traditional under arm crutch that has been made of a composite tubing design as a single 'y' shaped design. A large under arm cushion was designed and a service arm support was fitted to control the crutch during service.

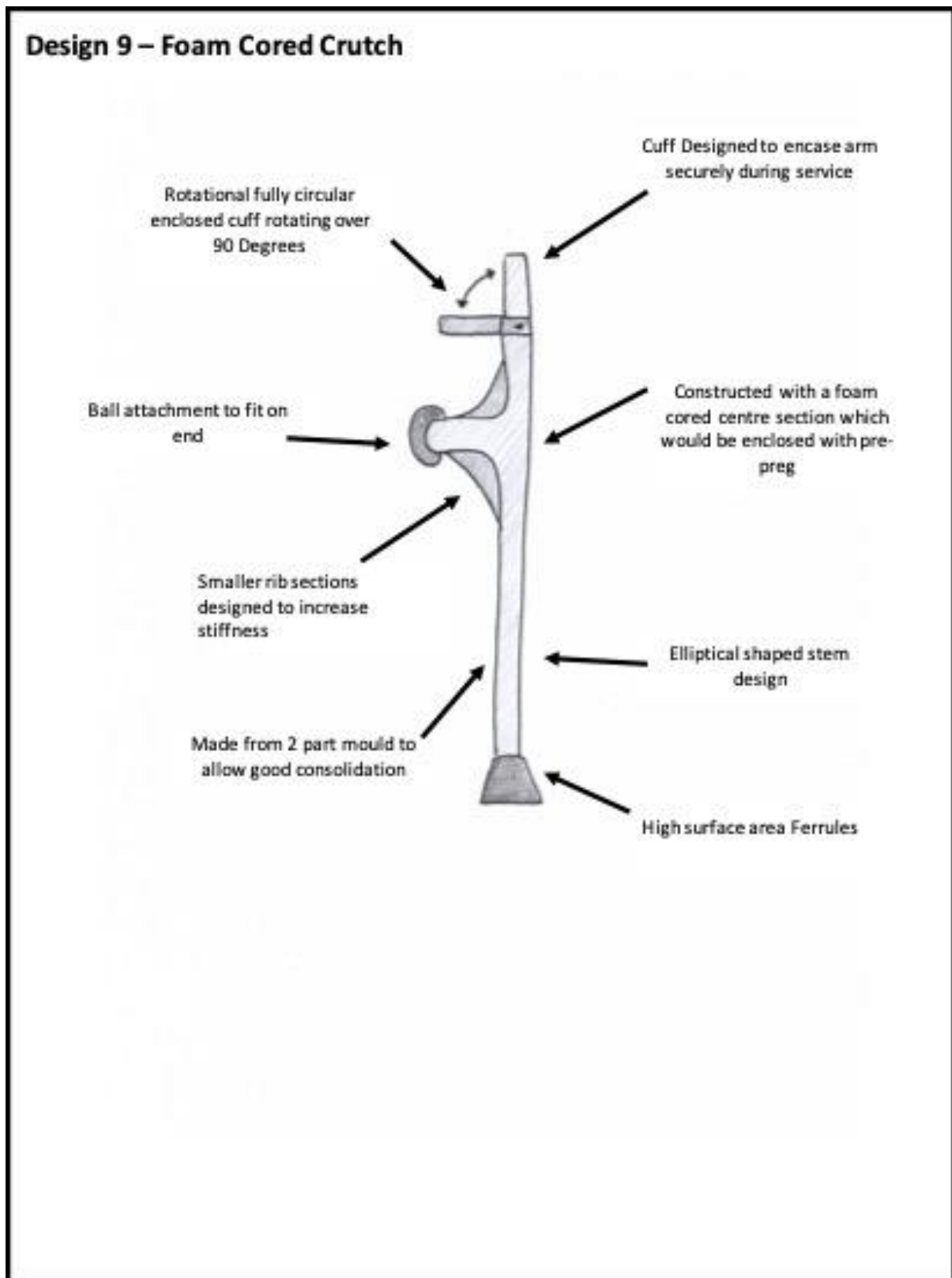
Elbow Crutch



**Figure 21:** Shows the full forearm being encased by a large Velcro strap with arm strap (cuff) to support upper arm. All built on a single composite tube with large surface area ferrule.



Foam Cored Crutch



**Figure 22:** Shows the Single Piece constructed foam cored composite crutch with integrated hand grip and adjustable arm support (cuff) design.

**Table 7:** Decision Matrix of Design Ideas - design 1 (Figure 16) was the highest ranked out of all the design developments this was due to its ability to produce a single large composite blade which once the mould is made would be easy to produce multiple times. Another factor is that all the support components can either be 3D printed or bought in, keeping the cost down and allow for multiple iterations to be made and spares can be produced if a component needs replacing at a competition.

| Category                               | Weighting /10 | 1          | 2          | 3          | 4          | 5          | 6          | 7          | 8          | 9          |
|--|---------------|------------|------------|------------|------------|------------|------------|------------|------------|------------|
| Support to arm                         | 10            | 7          | 9          | 10         | 7          | 5          | 8          | 5          | 8          | 7          |
| Benefits to Serve                      | 10            | 9          | 8          | 10         | 7          | 5          | 6          | 5          | 2          | 6          |
| Support to hand                        | 5             | 6          | 7          | 6          | 9          | 5          | 8          | 1          | 6          | 8          |
| Stability                              | 10            | 8          | 5          | 3          | 5          | 2          | 10         | 5          | 5          | 6          |
| Ease of manufacture                    | 8             | 6          | 2          | 6          | 10         | 4          | 5          | 6          | 6          | 10         |
| Cost of manufacture                    | 6             | 6          | 3          | 5          | 8          | 6          | 5          | 5          | 5          | 10         |
| Ease of movement                       | 8             | 7          | 6          | 8          | 7          | 5          | 5          | 7          | 4          | 8          |
| Ease to replace components             | 7             | 8          | 8          | 7          | 7          | 4          | 4          | 7          | 6          | 5          |
| Ease to manufacture support components | 5             | 10         | 8          | 6          | 7          | 5          | 4          | 7          | 5          | 5          |
| Ease to travel                         | 5             | 10         | 4          | 6          | 10         | 2          | 10         | 6          | 7          | 8          |
| Ability to use in everyday life        | 2             | 8          | 1          | 6          | 10         | 1          | 6          | 2          | 1          | 9          |
| <b>Total</b>                           | <b>760</b>    | <b>582</b> | <b>455</b> | <b>517</b> | <b>567</b> | <b>318</b> | <b>500</b> | <b>401</b> | <b>388</b> | <b>552</b> |

An area analysed in the decision matrix (Table 8) is the arm and hand components, these have varied over the different designs, ranging from: designs with straps, full circle designs, cylindrical arm sleeves and even multiple point circular arm supports. After showing all these to the athlete, the requirements were refined, and the design agreed, it was decided that the arm support needed to be simple and provide the strength so that force could be transferred, it must stay connected at all points during playing and finally must be easy to remove at any point during use.

The manufacture of the arm and hand support are the components that cause the biggest issue and require the largest amount of customisation. The arm support is a similar design to the current one but with a magnetic strap to ensure the support will not leave the arm during play. The Grip design remains similar to the current one, enhanced by a redesign locking mechanism which is integrated into the main stem design.

Chosen Initial Design

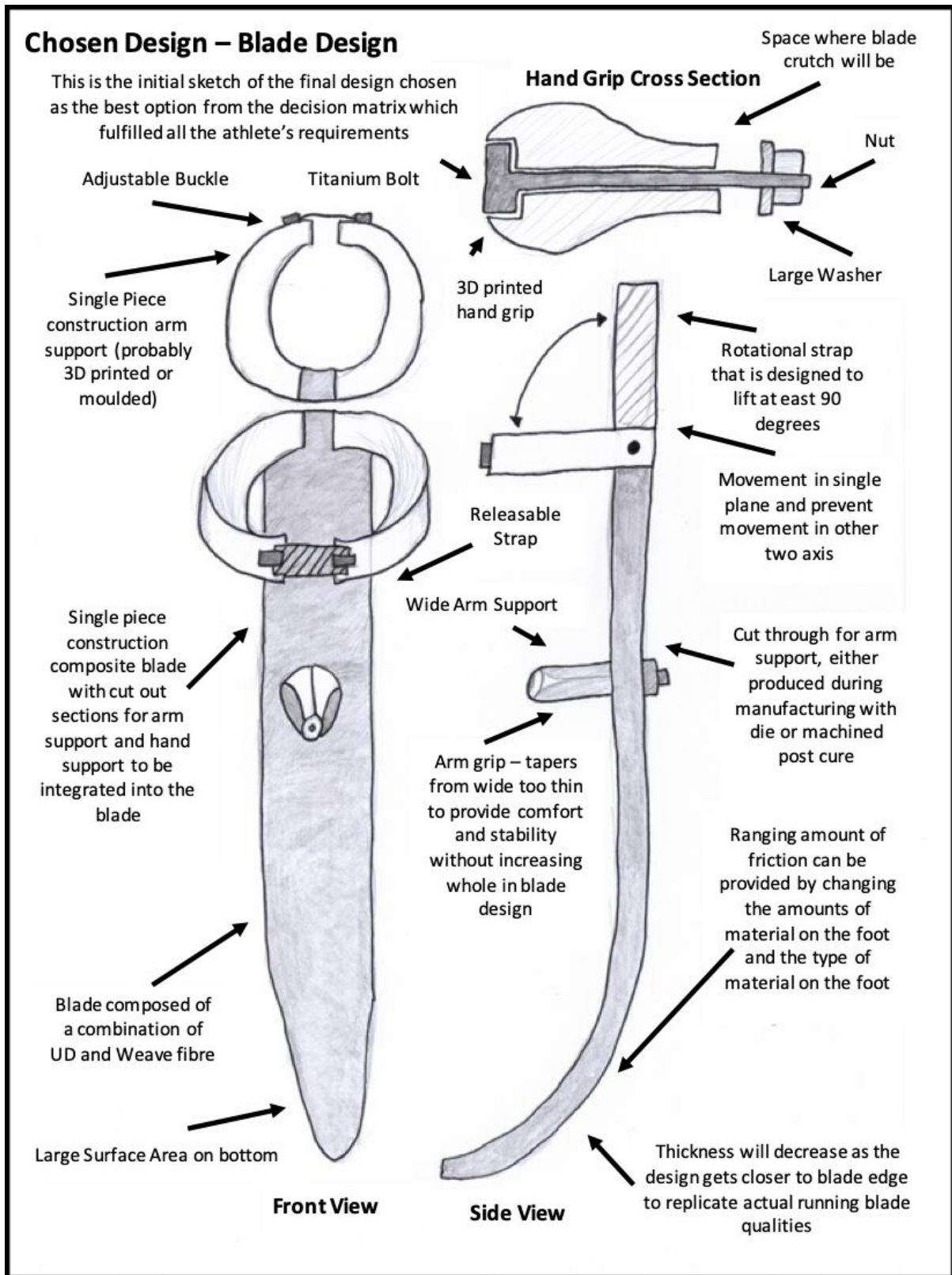


Figure 23: Blade Design – Chosen initial design from decision matrix.

**Tubular Design Analysis**

A tubular design was considered as a viable option and analysed (Table 9) with the ability to procure composite tubes and fabricate the desired shape. Including individually designed arm and hand grips, alternatively the production of a lightweight, foam cored tube encompasses hand grip and the arm grip manufactured separately. (Figure 24).



**Figure 24:** Shows a possible design for a composite tubing design manufactured from 2 composite tubes with either sleeve hand grip or (as shown) a integrated handle design. These ideas would produce very lightweight composite crutches, with the bought in tubing design being very cost affective.

**Table 8:** A table showing the positives and negatives of the Tubular Designs. The composite tube method could be seen as a financial benefit to improve the lives of people who use crutches in a non high-performance environment.

| Design   | Positives   | Negatives   |
|--|---|---|
| <b>Composite Tubing</b><br>&<br><b>Foam Cored Design</b> | <ul style="list-style-type: none"> <li>- Weight reduction</li> <li>- Desired hand grip design</li> <li>- Adjustable arm support (cuff) to improve service</li> <li>- Composite tubing could be bought in making the assembly process very easily</li> </ul> | <ul style="list-style-type: none"> <li>- Didn't improve interaction with floor at desired angles</li> <li>- Improved ferrule design wouldn't bring a greater benefit</li> <li>- Foam cored design requires expensive materials and manufacturing processes with no added benefit</li> </ul> |

The ability to cut tubing easily to correct size and 3D printing custom Hand and Arm grips would improve the comfort and recovery of long-term crutch uses.

**Material Selection**

Requirements are for the crutch to be made in multiples of 2 to allow the athlete to have a pair in everyday life, with a consistent performance from each crutch produced. (Table 10)

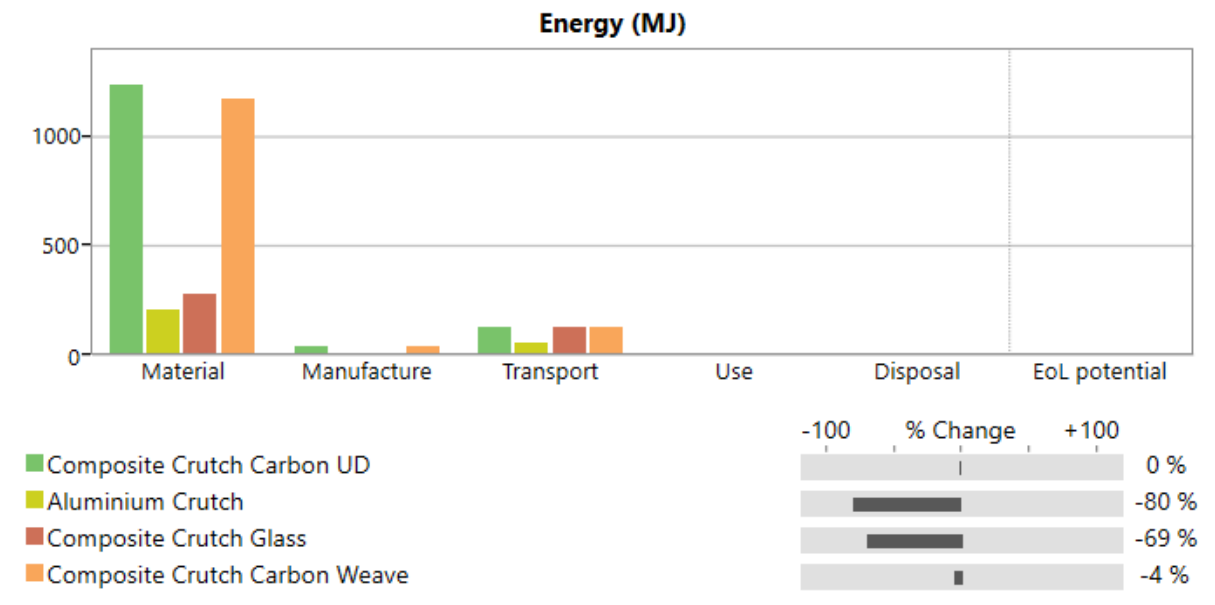
**Table 9:** A table showing the material requirements. The materials that were considered for the construction of this composite crutch were recommended by SHD Composites based on the following requirements

| Requirements of Materials  |
|--|
| <ul style="list-style-type: none"> <li>- High strength to weight ratio fibre</li> <li>- Consistent performance in both unidirectional and braid form</li> <li>- Best performance resin system with high strength to weight ratio as well as being able to perform in specified environment.</li> </ul> |

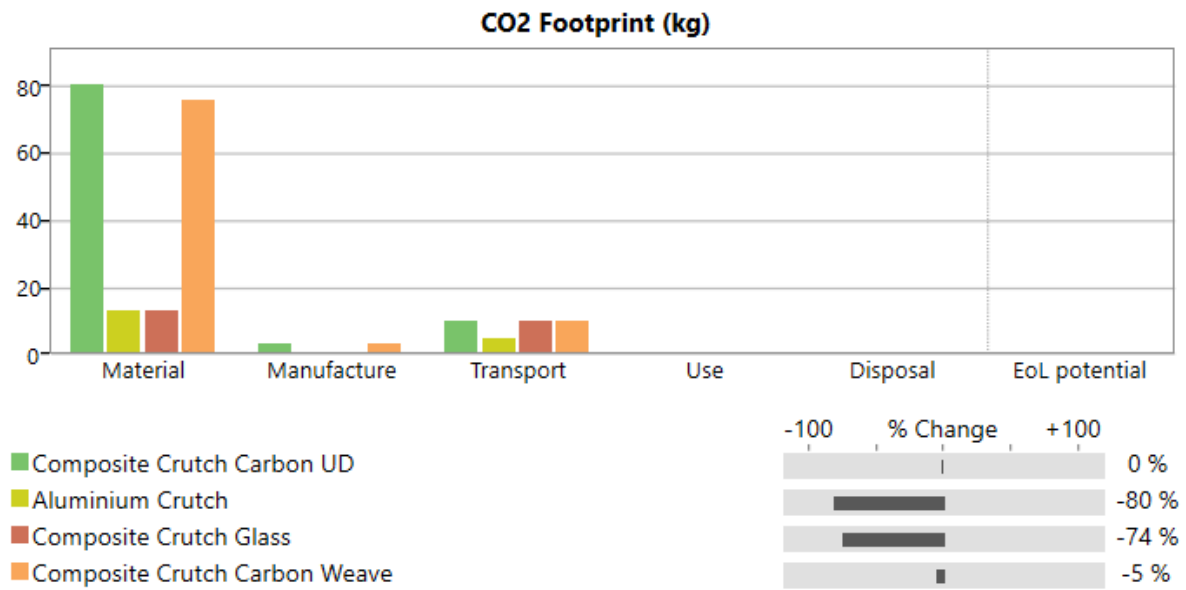
SHD Composites recommended a resin system which could be used in any of the manufacture techniques stated in Table 11 and provided the technical data for the resin along with the technical data for 400gsm Braid and UD Pre-preg which was used in the construction of both FEAs.

*Eco Audit*

An Eco Audit was produced for an aluminium crutch and different composite material choices, to compare the energy required for the manufacture processes. Figures 25 & 26 show the large increase in energy and CO2 emissions concluding that there is no environmental benefit to using carbon fibre but only a very small difference between aluminium and glass.



**Figure 25:** For each possible material selection the graph shows the energy required. Both carbon materials used considerably more energy than the aluminium and glass options with most of the energy being in material production rather than manufacturing and transport.



**Figure 26:** The graph shows that UD and Weave both create over four times more CO2 than aluminium and glass. Carbon also creates more during the manufacture stage of the process due to the autoclave.

**Manufacture Methods**

There are currently a wide range of manufacturing options in which the composite crutch could be produced, these were detailed in Table 11 and evaluated in the Decision Matrix (Table 12).

**Table 10:** Table of possible manufacture techniques.

| Method             | Description   | Discussion  |
|--------------------|---|---|
| <b>Hand Lay-up</b> | Wet layup is the production of a composite component by impregnating dry fibres with resin (usually applied by hand) with each ply stacked on top of each other and resin applied to each ply. A roller is usually applied to ensure that as much of the fibre is infiltrated and eliminating as much of the air bubbles as possible. | The final results produced by Hand Lay-up usually don't have the best mechanical properties this is due to the high risk that not all the fibres will be impregnated and that some air pockets will remain between the layers of fabric. This usually leads to undesirable volume fraction and the presence of voids, along with a poor surface finish. |
| <b>RIFT I</b>      | The process in which the chosen resin system flows through (in-plane) the fibres to impregnated every ply, pushing the air out of the fibres.   | This process allows for a desirable volume fraction and is much harder for complex parts and parts with a large amount of layers.   |

|                             |  |  |
|-----------------------------|--|--|
| <b>RIFT II</b>              | The process in which the chosen resin systems flows over the top of the composite and then seeps downwards into the fibres infiltrating and impregnating them.   | This process is used in lower quality products due to its production is much faster than RIFT I because the infiltration is going down this prevents air from being expelled as the air is forced downwards rather than out.   |
| <b>RIFT III</b>             | The process where resin is applied as a film rather than being forced through a vacuum. Once heated it impregnates the fumes which soak up resin which are consolidating between the plys.                                 | This process is very good at ensuring the fibres are fully impregnated and pushes a lot of excess air out of the composite.  |
| <b>RIFT IV</b>              | The process in which one side of a dry fibre is pre-impregnates on a single side which when heated consolidates with the other plys.   | The resin which is used in this process is specific and allows for a higher thermal resistance.  |
| <b>Filament Winding</b>     | The process in which a composite component is produced that has a axis of symmetry. The individual fibres are impregnated and then guided onto a rotating mandrel in a designated pattern.                                 | This technique is perfect to create a composite tube with the ability to change the orientation of lay-up of the fibres to achieve the desired properties with the exact same resin and fibre combination.   |
| <b>Compression Moulding</b> | The use of a bag or mould during the curing process in which the component or coupon (post resin application method) is sealed and then cured in a vacuum environment.   | This process is vital in all RIFT techniques causing the resin to flow through the fibres fully and reduce the presence of voids.  |
| <b>Pre-preg</b>             | Where the material before curing is already pre-impregnated with resin. Which is usually cured in an autoclave allowing the pressure and temperature to be completely controlled from the start to finish off the process. | This process is used for high end products as it will guarantee the desired properties and technical specification. The negativity of this technique is that it requires specific high temperature and pressure equipment. It does however lead to a very good surface finish. |
| <b>Post Cure</b>            | Post Cure is a technique used after one of the previous method is completed. Normally used when the component hasn't fully cured to finish off the product.  | This process prevents the component from warping and achieve the properties of the final product (for example Tg). This is usually more common with thicker components that contain more resin, with most being done in the original mould and under vacuum to reduce warping. |



These methods were analysed to decide which of the following would be best suitable for this project, focusing on the elements which I have considered as important and weighting them on how much effect each of these factors would have. (Table 11).

**Table 11:** Decision Matrix of Manufacture Techniques - From this decision matrix we were able to see that Pre-preg with a rating of 475 was the best option for production in University facilities, with access to an autoclave and the advantage of having guaranteed performance results over multiple products.

| Category                                      | Weighting /10 | Wet layup  | RIFT I     | RIFT II    | RIFT III   | RIFT IV    | Filament Winding | Compression Moulding | Pre-Preg   |
|---|---------------|------------|------------|------------|------------|------------|------------------|----------------------|------------|
| Stiffness                                     | 10            | 4          | 6          | 5          | 8          | 9          | 9                | 10                   | 10         |
| Surface Finish                                | 8             | 3          | 9          | 8          | 10         | 10         | 5                | 10                   | 10         |
| Volume Fraction                               | 8             | 4          | 6          | 5          | 8          | 8          | 8                | 9                    | 10         |
| Ability to achieve technical data             | 10            | 2          | 4          | 3          | 9          | 10         | 7                | 9                    | 10         |
| Time to manufacture                           | 5             | 10         | 4          | 5          | 6          | 7          | 6                | 6                    | 6          |
| Practicality for short run                    | 8             | 9          | 9          | 9          | 8          | 5          | 2                | 7                    | 8          |
| Cost to manufacture                           | 7             | 8          | 7          | 7          | 6          | 5          | 4                | 4                    | 3          |
| Possible to produce in University Facilities? | Yes or No     | Yes        | Yes        | Yes        | Yes        | No         | No               | Yes                  | Yes        |
| <b>Total</b>                                  | <b>560</b>    | <b>294</b> | <b>361</b> | <b>330</b> | <b>450</b> | <b>444</b> | <b>338</b>       | <b>456</b>           | <b>475</b> |

### 3D Printing Material Selection

For the manufacture of the Hand Grip and Arm Support assembly, prototypes were manufactured using PLA, the aim was to understand the printing mechanisms regarding specific geometry and allowing the athlete to evaluate the components. The final components do require mechanical strength and the ability to withstand a range of conditions during their use. Table 13 displays all options:

**Table 12:** Analysis of different materials available to be 3D printed. (Adapted from: Simplify 3D, 2020) The analysis was vital to choosing the correct material for the different components that need to be manufactured to complete the crutch assembly. 3D printing was selected due to the short production run and complexity of components.

| Category   | Positives   | Negatives  |
|--|---|--|
| <b>ABS<br/>(Acrylonitrile<br/>Butadiene Styrene)</b>                 | <ul style="list-style-type: none"> <li>- Low cost</li> <li>- Good impact and wear resistance</li> <li>- Good surface finish</li> <li>- Good heat resistance</li> </ul>                          | <ul style="list-style-type: none"> <li>- Heavy warping</li> <li>- Required a heated chamber or bed</li> <li>- Extraction is required</li> <li>- Dimensional inaccuracy</li> </ul>              |
| <b>Flexible<br/>(TPE or TPU)</b>                                     | <ul style="list-style-type: none"> <li>- Flexible and soft</li> <li>- Very good vibration dampening</li> <li>- Good impact resistance</li> </ul>  | <ul style="list-style-type: none"> <li>- Difficult printing process</li> <li>- High possibility of blobbing or stringing</li> <li>- May require specialist machines</li> </ul>                 |
| <b>PLA<br/>(Polylactic Acid)</b>                                     | <ul style="list-style-type: none"> <li>- Low cost</li> <li>- Stiff and good strength</li> <li>- Very good accuracy</li> </ul>   | <ul style="list-style-type: none"> <li>- Poor heat resistance</li> <li>- Requires cooling techniques</li> <li>- Filament is brittle before printing</li> <li>- Degrades under UV</li> </ul>    |
| <b>PETG<br/>(Polyethylene<br/>Terephthalate<br/>Glycol-modified)</b> | <ul style="list-style-type: none"> <li>- Smooth and glossy surface finish</li> <li>- Low warping</li> <li>- Odourless printing process</li> </ul>   | <ul style="list-style-type: none"> <li>- Can cause stringing during printing</li> </ul>  |
| <b>Nylon</b>   | <ul style="list-style-type: none"> <li>- Tough and partially flexible</li> <li>- Very good impact resistance</li> <li>- Odourless printing process</li> <li>- Resistance to Abrasion</li> </ul> | <ul style="list-style-type: none"> <li>- Warping can occur</li> <li>- Storage in vacuum required to prevent moisture absorption</li> <li>- Can only be used in certain environments</li> </ul> |
| <b>Carbon Fibre Filled</b>   | <ul style="list-style-type: none"> <li>- High strength and stiffness</li> <li>- Dimensional stability</li> <li>- Lightweight</li> </ul>   | <ul style="list-style-type: none"> <li>- Can damage the printing machine</li> <li>- Filament is brittle</li> <li>- Uneven flow can occur</li> <li>- Clogging can occur</li> </ul>              |
| <b>ASA<br/>(Acrylonitrile Styrene<br/>Acrylate)</b>                  | <ul style="list-style-type: none"> <li>- Strong UV resistance</li> <li>- High impact and wear resistance</li> </ul>   | <ul style="list-style-type: none"> <li>- Expensive</li> <li>- Requires heated nozzle</li> <li>- Extraction is required</li> </ul>  |

|                      |  |   |
|----------------------|--|---|
|                      | <ul style="list-style-type: none"> <li>- High glass transition temperature</li> </ul>  |   |
| <b>Polycarbonate</b> | <ul style="list-style-type: none"> <li>- Good impact resistance</li> <li>- Good heat resistance</li> <li>- Transparent</li> <li>- Bends without breaking</li> </ul>          | <ul style="list-style-type: none"> <li>- Requires heated nozzle</li> <li>- Warping can occur</li> <li>- Requires printing in vacuum to avoid moisture absorption</li> </ul> |
| <b>Polypropylene</b> | <ul style="list-style-type: none"> <li>- Good impact resistance</li> <li>- Good fatigue resistance</li> <li>- Good heat resistance</li> <li>- Good surface finish</li> </ul> | <ul style="list-style-type: none"> <li>- Warping is common</li> <li>- Low strength</li> <li>- May not stick to printer bed</li> <li>- Expensive</li> </ul>                  |
| <b>Metal Filled</b>  | <ul style="list-style-type: none"> <li>- Aesthetically appealing surface finish</li> <li>- Doesn't require heated nozzle</li> <li>- Heavy filaments</li> </ul>               | <ul style="list-style-type: none"> <li>- Can damage nozzle</li> <li>- Very brittle</li> <li>- Clogging is common</li> <li>- Expensive</li> </ul>                            |
| <b>Wood Filled</b>   | <ul style="list-style-type: none"> <li>- Aesthetically appealing surface finish</li> <li>- None expensive machinery</li> <li>- Pleasant odour</li> </ul>                     | <ul style="list-style-type: none"> <li>- Stringing occurs</li> <li>- Requires specific nozzles</li> </ul>   |

The final components have varying requirements and different materials were chosen. The arm support (Figure 27) requires a material which is comfortable to wear as well as withstanding the applied forces and not be reactive to the environment. The chosen material was TPE because it meets the desired qualities. TPE is also able to comply with the magnetic arm locking system. Also, its required properties, are maintained when coming into contact with stress or harsh environments due to its desirable abrasion resistance qualities. With the support being flexible the design can be made to fit completely to the arm of the athlete allowing for complete trust that the crutch will stay attached throughout use. The Hand Grip requires a strong material with strength in multiple axis and with good abrasion resistance. The arm grip components are to be made of Nylon this is the desirable material due to its ability to be strong with some partial flex. This component will be designed for competition, however, an ABS hand support will be produced, this is due to the effect of moisture has on Nylon over time causing deterioration therefore a second option can be used when not playing extending the life of the Nylon component.



**Figure 27:** Shows the Arm Supports system with its magnetic release strap. The system consists of two magnets that are enclosed in the arm support (cuff) and an elastic strap attached with 2 magnets. When closed it will be strong enough to hold the weight of the crutch on the athletes arm but also allow the athletes arm to remove from the cuff at any point.

#### *Prototype Arm and Hand Components*

A complete set of prototypes were manufactured from PLA to allow the athlete to handle the design providing valuable feedback, regarding sizing and comfort. (Figures 28, 29 & 30)



**Figure 28:** These prototypes were manufactured using PLA due to its low cost and easy access but most importantly no mechanical properties were required meaning the part could be printed with minimal fill to reduce cost and print time.



**Figure 29:** Prototype Arm Support (cuff) Top View



**Figure 30:** Shows the first prototype of the Hand Grip and Large Washer after being 3D printed from PLA. These two components will be held together by a titanium bolt and then integrated into the composite blade.

## Final Design

A final CAD model of final design (figure 31).



**Figure 31:** The final crutch assembly, consisting of the carbon fibre blade with sub-assemblies for the Hand grip and Arm Support (cuff). This model was produced to show the athlete and sponsors what the final crutch would look like allowing feedback before production. Unfortunately, due to Covid-19 the athlete has been unable to try the prototypes but will do so when possible before the final components are produced.

## Testing Methodology

### Hand Calculations from First Principles

Initial calculations were required to understand what is currently occurring in the athlete's crutch. Using Euler's Column Formula a rough estimate was created of the current crutches main tube to calculate the maximum force before failure.

Constants found in Table 19.

$$F = \frac{n\pi^2 EI}{L^2} \text{ therefore } F = \frac{1 \times \pi^2 \times 6.9 \times 10^9 \times 8.28425 \times 10^{-9}}{0.805^2} \text{ therefore } F = 8700N \quad [1]$$

The Area Moment of Inertia was calculated using Equation 2 and substituted into Equation 1.

$$I = \frac{\pi(d_o^4 - d_i^4)}{64} \text{ therefore } I = \frac{\pi(0.02387^4 - 0.01987^4)}{64} \text{ therefore } I = 8.28 \times 10^{-9}m^4 \quad [2]$$

The Buckling calculation for a composite beam of accurate dimensions to the final crutch design.

$$I = \frac{bh^3}{12} \text{ therefore } I = \frac{100 \times 10^{-3} \times (15 \times 10^{-3})^3}{12} \text{ therefore } I = 2.8125 \times 10^{-8} m^4 \quad [3]$$

Which is used in Equation 4

$$F = \frac{n\pi^2 EI}{L^2} \text{ therefore } F = \frac{1 \times \pi^2 \times 231 \times 10^9 \times 2.8125 \times 10^{-8}}{(2 \times 0.95)^2} \text{ therefore } F = 17762.2N \quad [4]$$

With Equation 4 showing that the composite blade column could have a maximum buckling force of over twice that of the aluminium tube. This value is not accurate for the final design due to the thickness varying and complex geometry.

### Coupon Manufacture

To validate the FEA coupons were manufactured and tested following the manufacture process where figures 32, 33, 34 show the pre-curing procedure. This material did differ slightly to the technical data sheet which the Solidworks model, that used the material for MTC400-1-C200T-M46J-6K-42%RW-1250, the resin system is the same but the fibre is slightly different, meaning the material should perform in the same way but the test samples should fail at a lower point but the resin should perform in the same way. For the FLEX test the standard was to produce a sample that has a thickness of 2mm, on the data sheet provided the cured plied thickness (CPT) was 0.228mm.

$$\text{Number of plies} = \frac{\text{Desired Thickness}}{\text{Cured Ply Thickness}} \quad [5]$$

By following this equation 5 the number of plies was 8.77 but this was rounded down to 8 plies.



**Figure 32:** the pre-preg plate, pre-cure, pre-bagging and autoclave process. The sample material was provided by SHD Composites, 3 x 400mm x 400mm sheets of MTC400-1-C200T-HS-3K-42%RW-1250.





**Figure 33:** autoclave control panel.



**Figure 34:** composite plate on fully pre-prepared glass plate, enveloped bag with valves attached to the pipes in the autoclave and temperature sensor on the component to ensure there is no leakage in the bag and the plate is at the temperature specified.

### **Coupon Testing**

Coupons were then tested by following *BS EN 14125:1998+A1:2011* on an Instron (Figure 35) and the values extrapolated from the testing machine. These values were then used to calculate Flexural Modulus and Strength as well as the Ultimate Tensile Strength. The samples were then analysed under a microscope and comparison of strength and modulus against the theoretical values which were predicted.

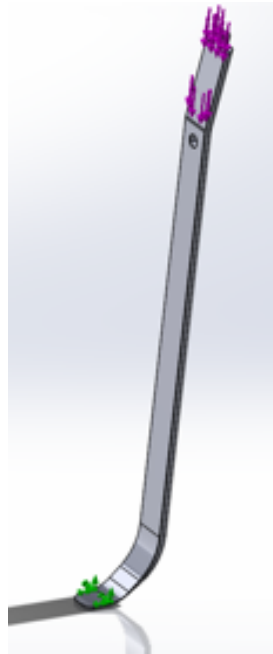


**Figure 35:** Instron testing machine, performing 3 point FLEX test for the individual coupons which were cut from the composite plate.

### **FEA Models**

#### *Setup*

The Solidworks simulations that were created were static load studies, the material is expected to act linearly (follows Hooke's Law) and this decision can be justified from the test result graphs which act linearly before failing meaning Hooke's Law is being obeyed by the material. The main decision was the FOS which had a failure criterion of Tsai-Wu which was chosen because it models the component as having unequal strength in tensions and compression which is how composites especially carbon fibre are expected to react. Two possible scenarios were possible, one were the force being applied through the arm support section, the other being a reaction force (equal to the arm support force) from the ground shown in Figure's 36 & 37.



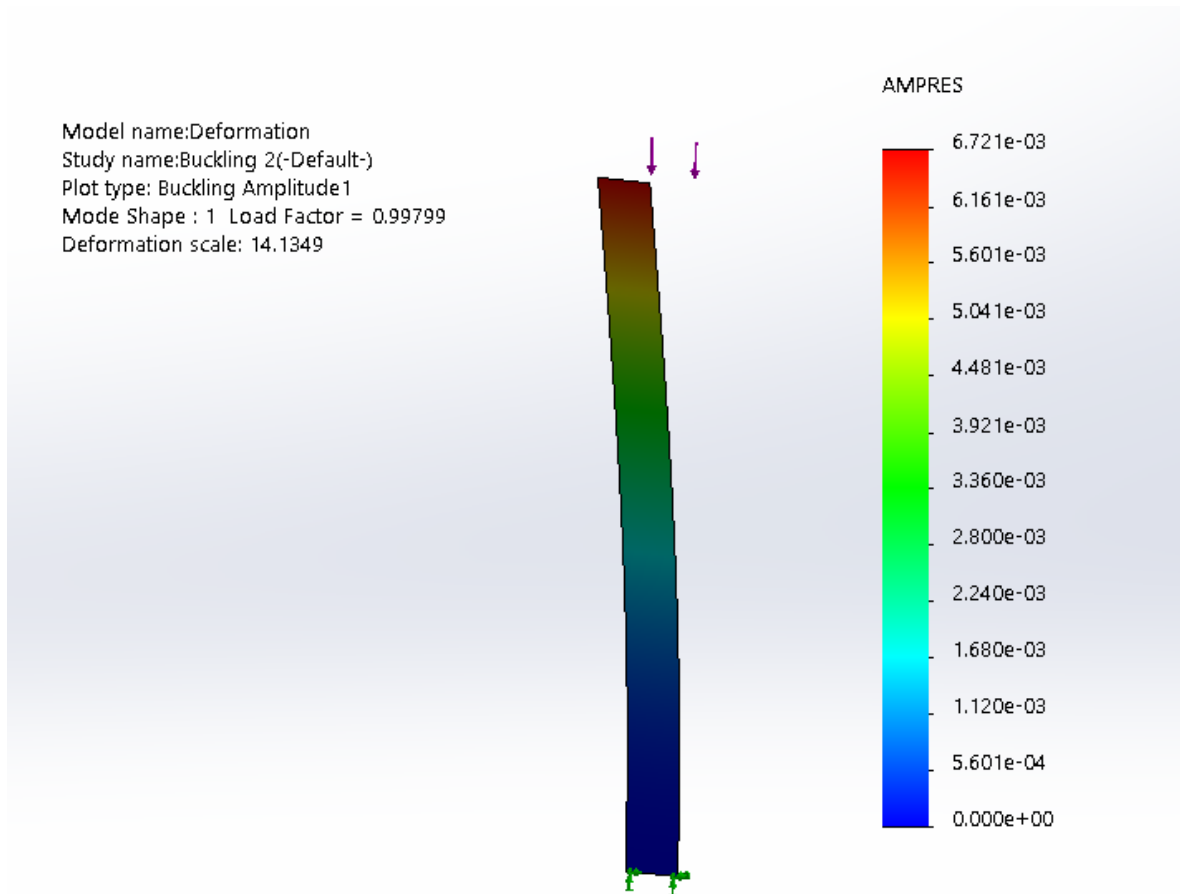
**Figure 36:** Image of CAD Crutch with loading points at the top and fixed at the bottom, the force applied is not at the 80 degree angle of the top component but instead is applied throughout the top face vertically down. The Load (1000N) was applied as during in testing the biggest stress was roughly 40kg so a safety factor of 2.5 could be seen if the crutch could withstand this load.



**Figure 37:** Image of CAD Crutch with loading points at the bottom and fixed at the top, the top being fixed at the whole of the top face due to that being between the two places the athlete interacts with the crutch making deformation there very unlikely due to the strength of that area. The Load (1000N) was applied as during in testing the biggest stress was roughly 40kg so a safety factor of 2.5 could be seen if the crutch could withstand this load.

### Validation

To validate this FEA model a buckling simulation was created, due to the crutch being considered a slender component, based off the first principal calculations seen in Equation 4, the model was used to ensure that the mechanical data inputted into the Solidworks model reacts in a realistic manor. For the composite main beam section, the critical buckling force is 17700N and was modelled under the same material data used in the all other FEA simulation (Figure 38) with the results showing that the beam buckled at 17000N which was a percentage difference of 0.201% which helps validates all models. This clearly shows that the mechanical data being used in all FEA models can be considered accurate to first principal calculations, validating all further models produced.



**Figure 38:** Shows the deformation study (Buckling) of the composite beam based on the dimensions of the main crutch body using material data which was used in all other FEA studies. Buckling occurs mathematically when the stiffness becomes singular at that point the determinant becomes zero causing the beam to become inverted meaning the model deforms into the buckled shape.

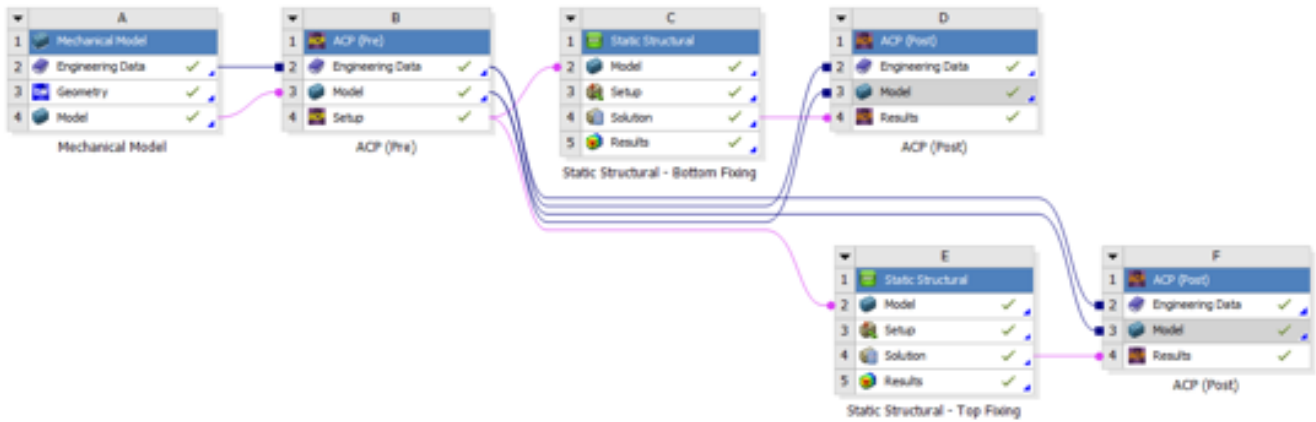
## 9.4 Crutch Modelling

### *Ply Selection and Model Dimensions*

*As the crutch was modelled the plies were laid up with the UD fibres in the Centre and then a few layers of braid round the outside to provide the strength during twisting motion as well as improve impact resistance/toughness.. The ratios and*

number of the two types of pre-pregs braid and UD in each section were changed until the final design was able to withstand the expected conditions.

### 9.4.2 ANSYS model

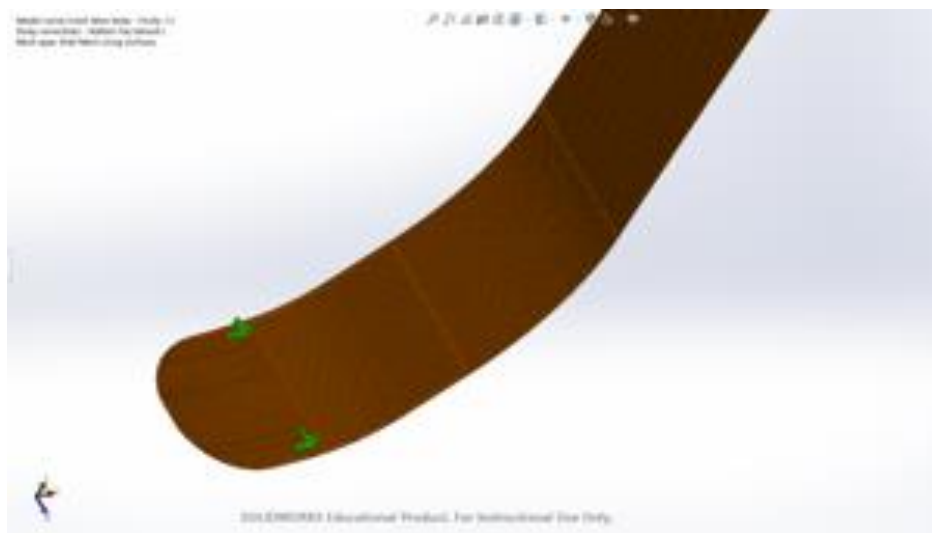


**Figure 39:** A secondary analysis tool which was used in this project was the ANSYS composite analysis tool, with the purpose of reducing uncertainty in the theoretical models and analysis of the failure modes. ACP was chosen as it is ANSYS's composite analysis tool, with a static structural modelling tool due to the forces experienced by the crutch being simplified to the worst-case scenario as a single load. With the two scenarios being modelled in separate studies but using the same composite setup to allow the result to be comparable.

The model was made, by creating the 2 material profiles of the UD and Braid by adapting the materials data for the high strength modulus pre-preg to match the properties of the provided technical data. Recreating the layup in ANSYS's stack up section, laying out the orientation of each different section with each defined by an individual rosette which defines the axis for each of the sections as the angles change mirroring the Solidworks model. The forces however, for the ANSYS model were modelled differently with the forces being applied on the edges and being fixed on parts.

### 9.4.3 Mesh Dependency

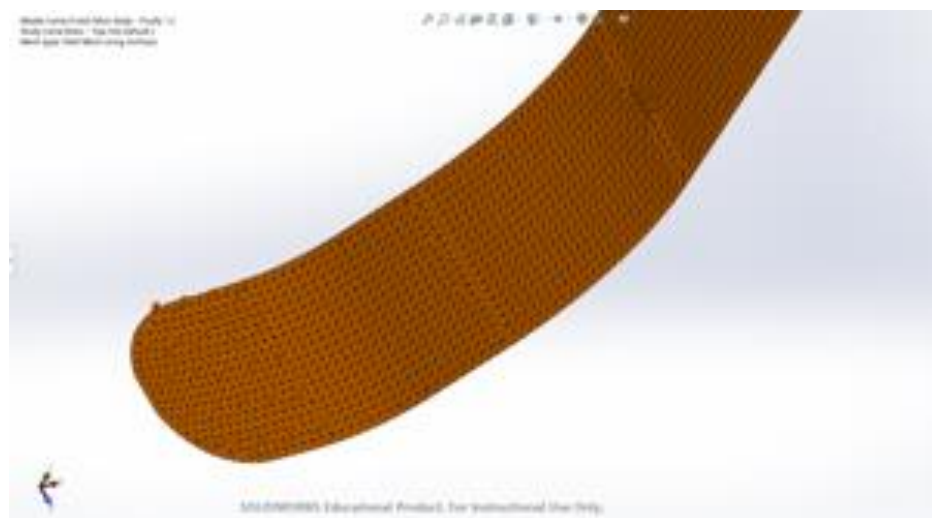
For both simulation tools a full mesh independency study was created, this allowed for the results not to be affected by the discretisation errors occurring due to mesh sizing. By changing the global element size, from 0.75mm to 12mm, produced a complete range of number of elements per study which are seen in Figure's 40, 41, 42, 43 & 44.



**Figure 40:** 1.5 mm element size mesh.



**Figure 41:** 2.25 mm element size mesh.



**Figure 42:** 3 mm element size mesh.

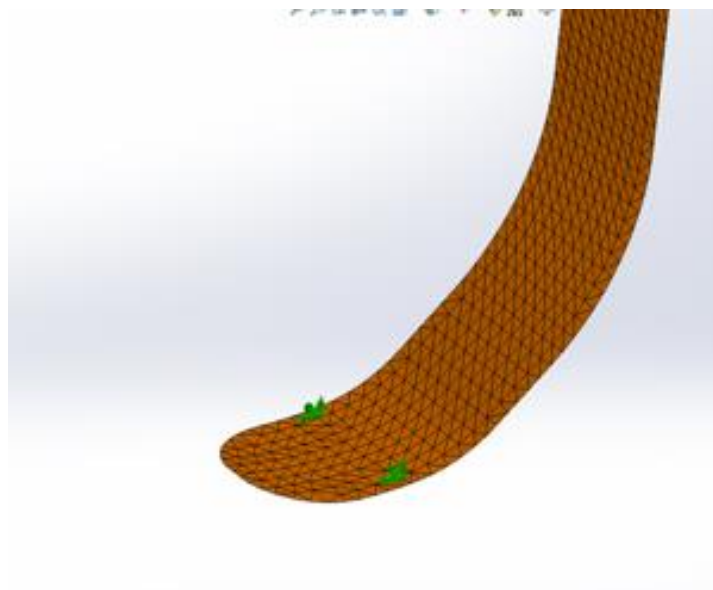


Figure 43: 6 mm element size mesh.



Figure 44: 12 mm element size mesh.

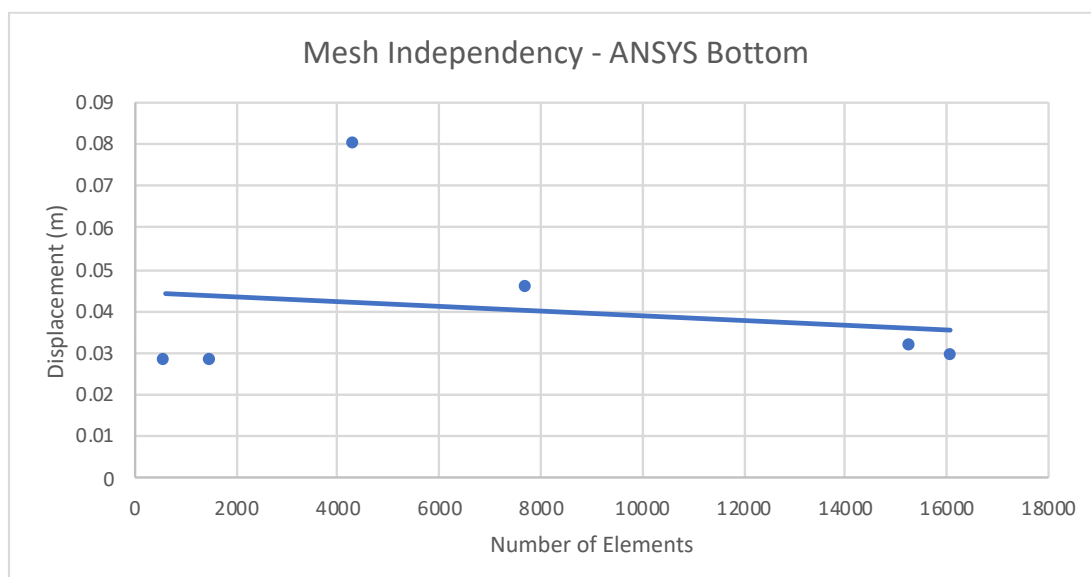
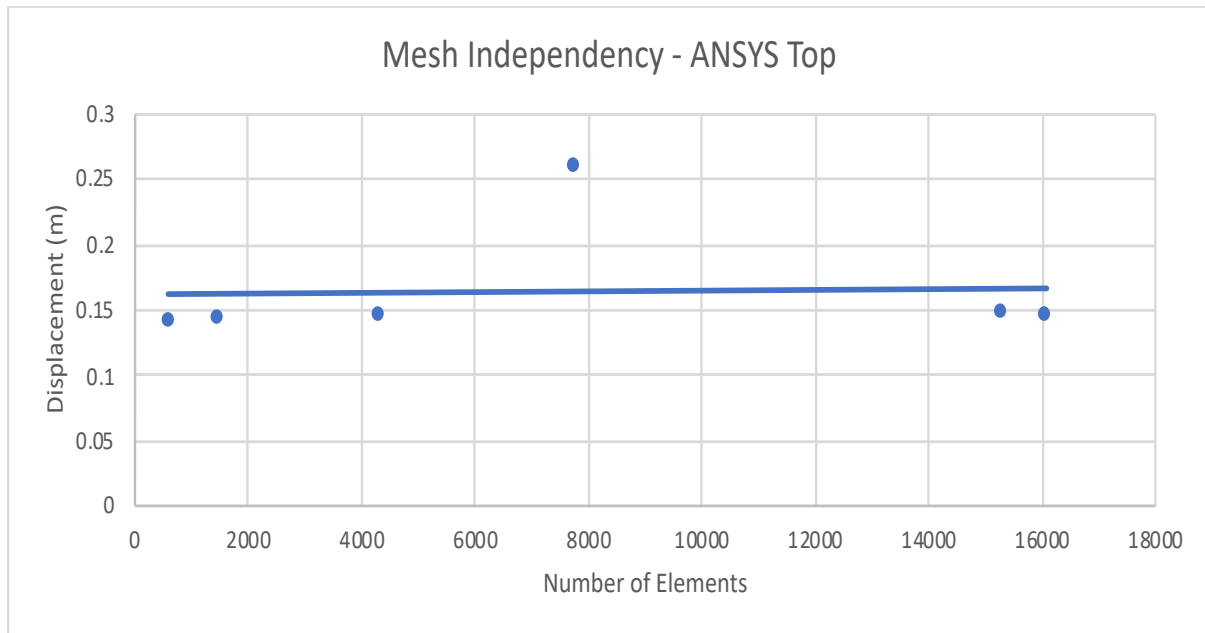
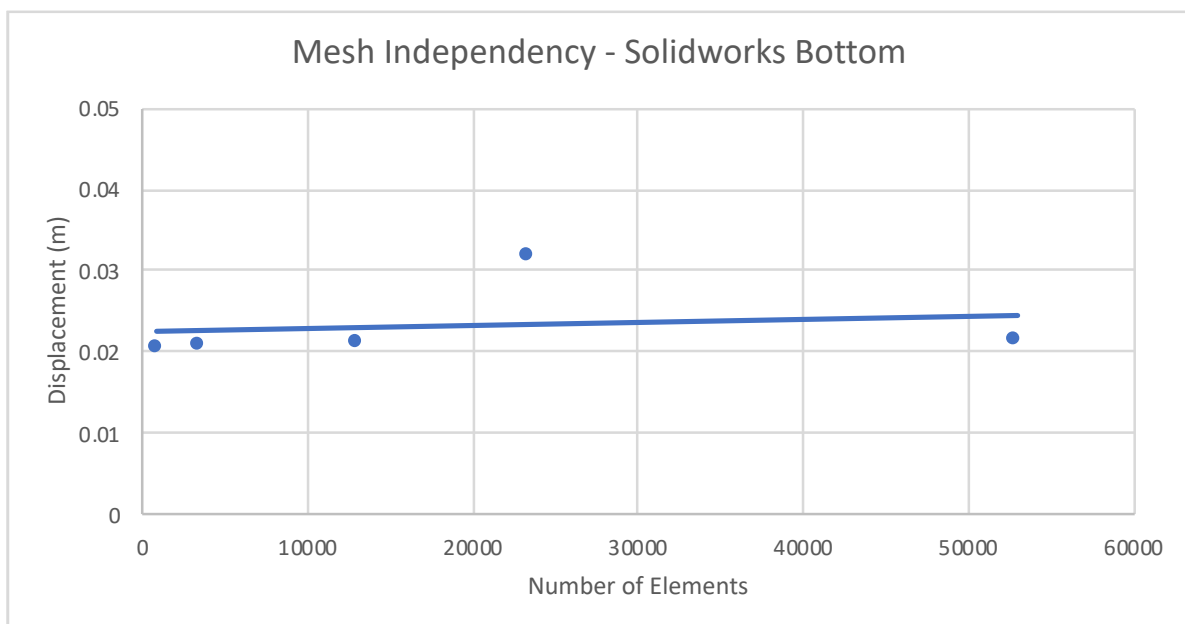


Figure 45: Mesh Independence study models using the ANSYS software. with ANSYS bottom model settling at 0.03m

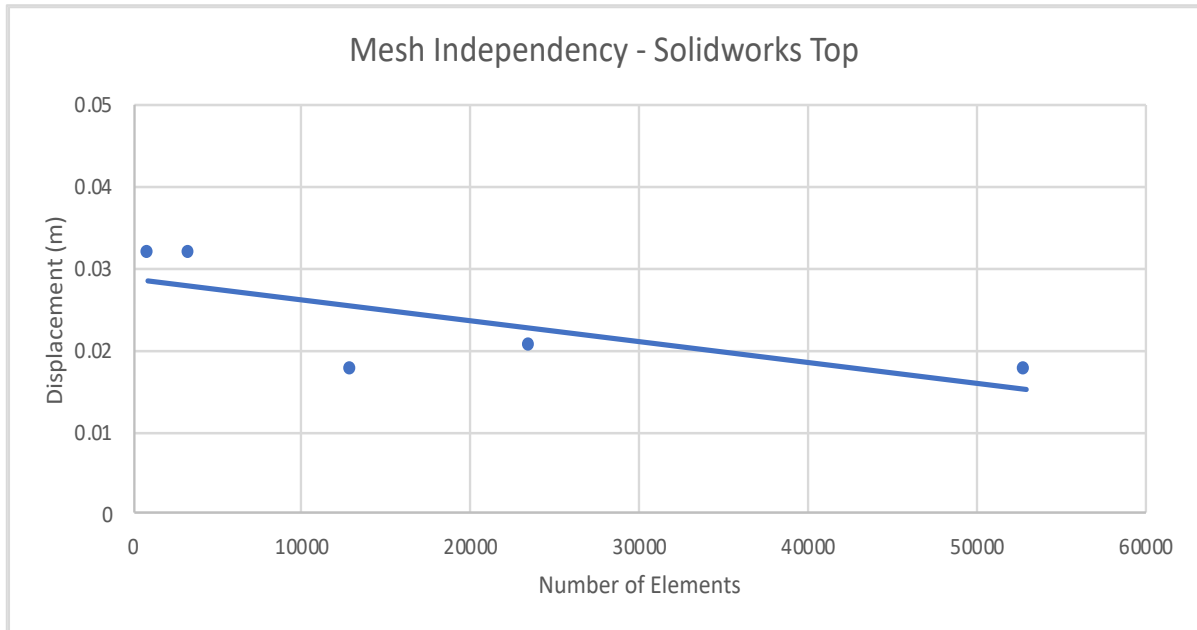


**Figure 46:** Showing the Mesh Independence study models using the ANSYS software. the top model settling at 0.15m (this model is considered an anomaly when compared to other 3 simulations).



**Figure 47:** Showing the Mesh Independence study for models using the Solidworks software. With the Solidworks models showing a bottom model settling at 0.02m





**Figure 48:** Showing the Mesh Independency study models using the Solidworks software. With the Solidworks models showing the top model settling at 0.02m once elements passed 10,000.

The results from Figure’s 45, 46, 47 & 48 show that for all of the studies there was a clear trend that the data was mesh independent when compared against element number and displacement, this can be seen in all of the graphs but with some showing some anomalies. This unexplained error for the bottom fixed values should be removed and considered an anomaly. But despite this value all the other values show a pattern where the mesh is independent.

## Results

### Coupon Testing

The Coupons were tested following the method (see Table 14).

**Table 13** - results from coupon testing.

|                                  | <b>Carbon Pre-preg Weave</b> | <b>Units</b>           |
|----------------------------------|------------------------------|------------------------|
| <b>Width</b>                     | 15.0 (0) (0%) 11/11          | <i>mm</i>              |
| <b>Thickness</b>                 | 1.58 (0.01) (0.67%) 9/11     | <i>mm</i>              |
| <b>Vf</b>                        | 0.49                         | -                      |
| <b>CPT</b>                       | 0.20                         | <i>mm</i>              |
| <b>Flexural Modulus</b>          | 61.6 (2.33) (3.79%) 8/11     | <i>N/m<sup>2</sup></i> |
| <b>Flexural Strength</b>         | 799 (39.9) (5%) 9/11         | <i>N/m<sup>2</sup></i> |
| <b>Ultimate Tensile Strength</b> | 807 (36.9) (4.57%) 10/11     | <i>Mpa</i>             |

The upper and lower bound was calculated using the values from the 11 samples provided, see table 15:

**Table 14:** Upper Bound (Kelly Tyson) and Lower Bound (Hookes) were calculated using equations referenced in the table. Both bounds have been analysed and calculated in section 11.1.

|                              |                   | CF Braid     | Units      |  |
|------------------------------|-------------------|--------------|------------|--|
| Lower Bound<br>(Hookes)      | $E_c$             | 59.75        | <b>GPa</b> | ROM  |
|                              | $\epsilon$        | 0.016        | -          | (Tecknowledge, 2020)                                 |
|                              | $\sigma_c$        | <b>1046</b>  | <b>MPa</b> | $\sigma_c = \epsilon \times E_c$ [6]                 |
| Upper Bound<br>(Kelly Tyson) | <b>UTSF</b>       | <b>3750</b>  | <b>MPa</b> | (Tecknowledge, 2020)                                 |
|                              | <b>vf</b>         | <b>0.476</b> |            | Appendix K   |
|                              | <b>UTSm</b>       | <b>22</b>    | <b>MPa</b> | Appendix K   |
|                              | $\sigma_c$        | <b>1773</b>  | <b>MPa</b> | $\sigma_c = (UTSF \times vf) + (UTSm \times Vm)$ [7] |
| Test Data                    | <b>First Drop</b> | <b>766</b>   | <b>MPa</b> | Flex Test  |
|                              | <b>UTS</b>        | <b>807</b>   | <b>MPa</b> | Flex Test  |

## FEA Simulations

### Buckling

A buckling study was completed on Solidworks as an initial testing scenario to ensure the crutch was capable of surviving the expected loads in addition to understanding at what force the crutch would be expected to buckle, see Table 16.

**Table 15** - Showing the expected load factor at which the crutch will buckle.

| Solidworks         |                            |
|--------------------|----------------------------|
| <b>Load (N)</b>    | 1000                       |
| <b>AMPRES</b>      | 0.027 (0.0046) (16.6%) 5/5 |
| <b>Load factor</b> | 5.33 (3.06) (57.3%) 5/5    |

### Static Test – Bottom Fixing

The results from the static testing with the fixing at the bottom can be seen in Table 17.

**Table 16:** Showing the results from the bottom fixing simulations where both the Solidworks and ANSYS models have been evaluated into the four categories in which the simulations are analysed.

|                             | Solidworks Model               | ANSYS Model                  |
|-----------------------------|--------------------------------|------------------------------|
| <b>Displacement (mm)</b>    | 23.0 (7.03) (30.6%) 6/6        | 40 (20.5) (50.7%) 6/6        |
| <b>Strain</b>               | 0.000408 (0.000433) (106%) 6/6 | 0.0047±0.0028 (58%) 6/6      |
| <b>Stress (MPa)</b>         | 132 (79.2) (0.00006%) 6/6      | 178±0.00017 (0.0000976%) 6/6 |
| <b>Factor of Safety FOS</b> | 1.02 (0.333) (32.8%) 6/6       | 2.19 (0.834) (38.1%) 6/6     |

### Static Test – Top Fixing

The results from the static testing with the fixing at the top can be seen in Table 18.

**Table 17:** Showing the results from the top fixing simulations where both the Solidworks and ANSYS models have been evaluated into the four categories in which the simulations are analysed.

|                             | Solidworks Model                | ANSYS Model                     |
|-----------------------------|---------------------------------|---------------------------------|
| <b>Displacement (mm)</b>    | 22.92 (4.43) (19.3%) 6/6        | 163.7 (46.5) (28.6%) 6/6        |
| <b>Strain</b>               | 0.000894 (0.000436) (48.8%) 6/6 | 0.0071 (0.0042) (59.7%) 6/6     |
| <b>Stress (MPa)</b>         | 88.5 (74.3) (84.0%) 6/6         | 332 (0.000162) (0.0000488%) 6/6 |
| <b>Factor of Safety FOS</b> | 0.974 (0.236) (24.2%) 6/6       | 0.875 (0.53) (60.6%) 6/6        |

## Discussion

### Coupon Production and Testing

An error was made during the creation of the coupons leading to their thickness being less than what the British Standard requires, this was due to a wrong assumption being made. The assumption of a CPT of 0.228mm was wrong and was actually 0.2mm meaning the number of plies should have been 10 by using equation 5.

$$n = \frac{V_f \times \rho_f \times t}{A_f} = \frac{0.49 \times 1800 \times 0.002}{0.17} = 10.4 \sim 10 \text{ Ply's} \quad [8]$$

This error does mean there is a greater chance for uncertainty to have a greater effect on the results, this is because the Span/Depth ratio of  $\approx 40$  shows that the coupons are very thin at an average thickness of 1.58mm compared to the British Standard requirement of 2mm. This will have an effect on the results with the coupons being unable to deform as much as the standard sized coupons, the uncertainty from this error is considered not relevant to the final design as the final thickness is 4mm, the load scenario will differ for the final crutch where the load and fixing will be at the ends of the crutch where failure by compression is expected.

### Validation Techniques

For the FEA simulations a comparison of Flexural Modulus was completed for both materials, this difference should show a similarity to the factor of safety produced from the simulation.

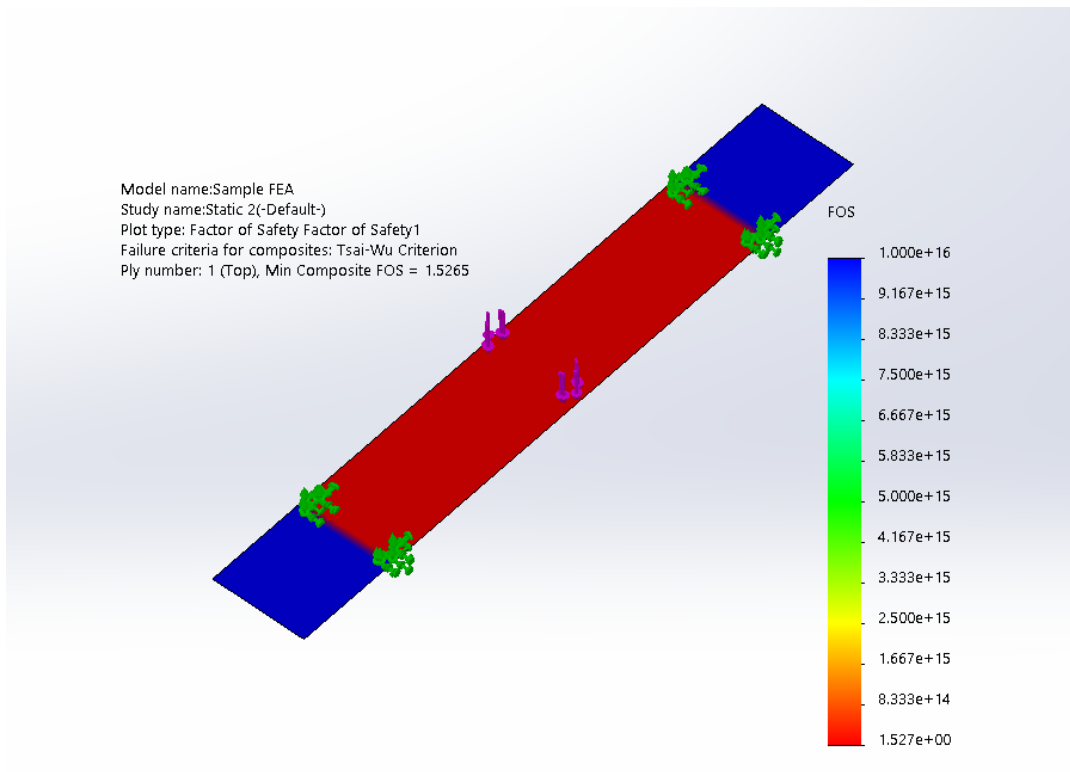
- High Strength Material Data – Flexural Modulus – 93.6GPa
- Coupon Test Data – Flexural Modulus – 61.6 GPa (Table 14)
- FOS from the FEA model of 1.53 (Figure 49)

The difference between the high strength material and test data had a difference of 1.52 meaning the percentage difference compared to the FOS is 0.49%.

This validation method is not completely valid, it would be preferred if technical data was available for the coupon material, creating an FEA model with this data, then validating it against displacement and max load of failure.

The other validation was done through the comparison against the Rule of Mixtures calculation to see how the Flexural Modulus compared. Equation 6.

$$E_c = K\eta_l\eta_oV_fE_f + V_mE_m = (1 \times 1 \times 1 \times 0.49 \times 231) + (51 \times 6.6) = 60\text{GPa} \quad [9]$$



**Figure 49:** FOS failure mode of the simulation coupon with the maximum load being 306N and shows a FOS of 1.53. The percentage difference between FOS and Flexural Modulus is so small it could easily have been affected by a calibration issue or a small anomaly in the results caused by the reduced thickness.

The full set of 11 results when compared to the Rule of Mixtures results had a percentage difference of 10%, Test data = 66.8 GPa and the ROM = 60.0 GPa. There are multiple reasons for the difference between the results, the first being that if exclude samples A1, A2 and A3 due to these values being especially high compared to the rest of the results, you see that the test data mean changes to 61.60 GPa and reducing the percentage difference down to 2.6%.

This variation over the range can be explained by the reduced thickness of the coupons, which could have caused the variation when the first drop occurs, with these 3 samples showing a large difference between the Initial Load Drop or point where the graph stops acting linearly and the Max Load drop. This meant that the reduced displacement increased the slope value and therefore increased the Flexural Modulus. This can be explained by the way the first drop or the point in which the material stopped acting linearly was all analysed by human interpretation which could lead to data being misinterpreted. Other values have the First Load Drop and Max Load Drop being identical this can be explained by the pre-preg having failed due to multiple shear points, causing the fibres to debond from the matrix and fracture. This occurred due to the coupons being made of high modulus pre-preg,

where there may have been first ply failure but with complete failure occurring almost instantaneously making the detection of a First Drop impossible for nearly all samples.

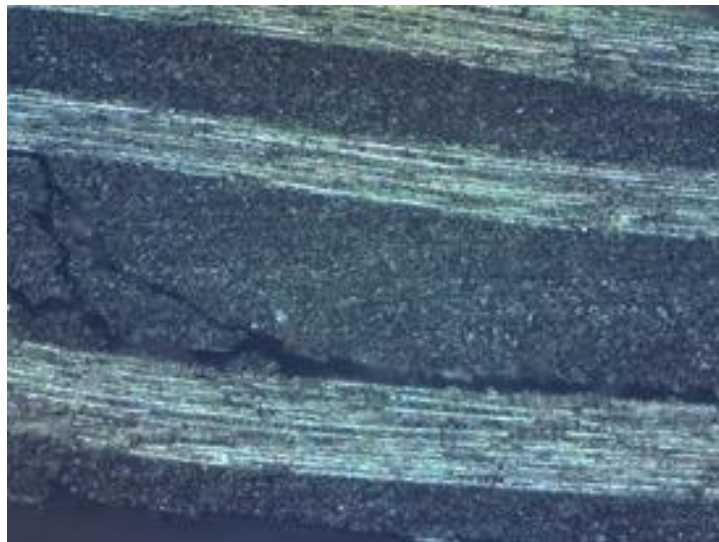
For all hand calculated values there was a large difference between the tested values, this can be explained by the following assumptions. The ROM fibre strength ( $E_f$ ) was assumed to be 231GPa which was taken from material data of very similar fibres affecting the Flexural Modulus value. (Table 19).

**Table 18:** Showing the Upper and Lower Bound of the test data. It was assumed the lower bound strain failure of 1.6% was taken from the same material data as the fibre strength, when analysing the data a more appropriate value was deemed to be closer to 1%. The upper bound also had assumptions with the UTSF and UTSm values all coming from technical data based on suspected or of a very similar acting material, this produced a value which can be considered reasonable but not accurate.

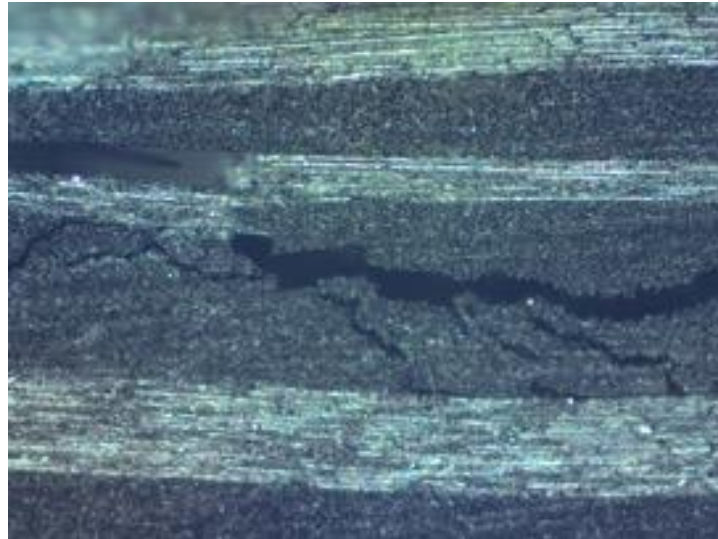
|               |                              | CF Braid     | Units      |  |
|---------------|------------------------------|--------------|------------|--|
| Lower Bound   | $E_c$                        | 59.75        | <b>GPa</b> | ROM  |
| (Hookes)      | $\epsilon$                   | 0.016        | -          | (Tecknowledge, 2020)                                   |
|               | $\sigma_c$                   | <b>1046</b>  | <b>MPa</b> | $\sigma_c = \epsilon \times E_c$ [6]                   |
| Upper Bound   | <b>UTSF</b>                  | <b>3750</b>  | <b>MPa</b> | (Tecknowledge, 2020)                                   |
| (Kelly Tyson) | <b>vf</b>                    | <b>0.476</b> |            | Appendix K   |
|               | <b>UTSm</b>                  | <b>22</b>    | <b>MPa</b> | Appendix K   |
|               | <b><math>\sigma_c</math></b> | <b>1773</b>  | <b>MPa</b> | $\sigma_c = (UTSF \times V_f) + (UTSm \times V_m)$ [7] |
| Test Data     | <b>First Drop</b>            | <b>766</b>   | <b>MPa</b> | Flex Test  |
|               | <b>UTS</b>                   | <b>807</b>   | <b>MPa</b> | Flex Test  |

### Microscope

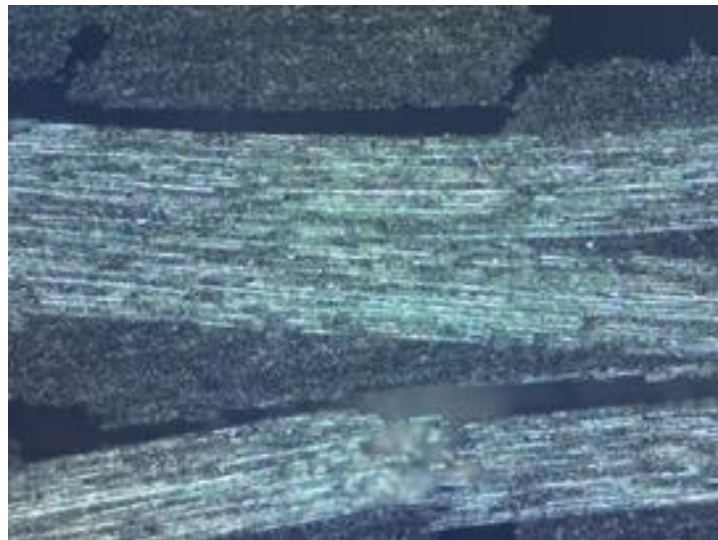
The failure of the coupons can be seen in these optical micrographs (figure 50, 51 & 52) with clean acceptable failure modes the samples underwent complete failure. These figures were used to see if any voids, air bubbles, inclusions or early fibre breaks had occurred which may have caused the test result to not achieve the expected values.



**Figure 50:** Shows matrix cracking in the composite with a debonded interface along the face of the fibre.



**Figure 51:** Shows fibre fracture has occurred, along with an accumulation of micro cracks with some cracks becoming perpendicular to the fibre direction.



**Figure 52:** Shows multiple interface debonding, with some matrix cracking becoming perpendicular as well as fibre bending and fibre pull-out.

The figures above show expected failure modes with no clear presence of voids or any other defect in the coupon meaning the manufacture method can be seen as consistent to material data or model data, improving the confidence in all CAD models.

### **Calibration of Equipment**

The 3 point flexural test (BS EN 2562:1997) was conducted on a Instron Universal Testing Machine 3345 K1699, Instron 500N force transducer 2519-107 (serial number 51499). The Instron calibration had expired (certificate: E230032116110441 from 21<sup>st</sup> March 2016 to 21<sup>st</sup> March 2017) The machine was reset (calibrated by zeroing) with displacement errors removed from the calculations during data extrapolation from the graphs. When analysing the data it can be agreed that the lack of calibration has had minimal effect on the data and any systematic error in the device has been removed where possible. (Figure 53).

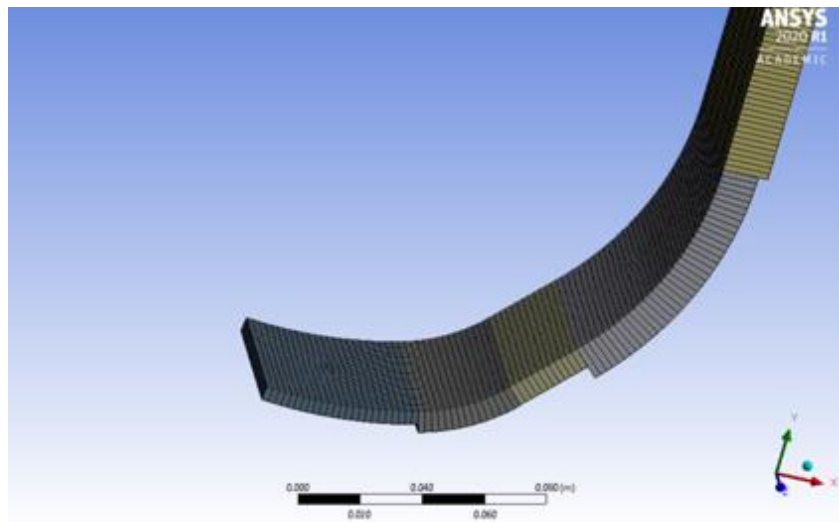




**Figure 53:** The measurements for the whole experiment were completed with the same rule and the same micrometer, however none of the equipment was calibrated as per BS 870:2008, hence there is an increased uncertainty with the collected data. No calibration block was available, measurement with an alternative device recorded the same value with an acceptable level of difference, this matches the accepted level of uncertainty therefore increasing the confidence in the results. If these measurements were repeated, then it would be preferable for these to occur on a commercially calibrated machine or by using a test sample with a known strength value to understand if any error is present.

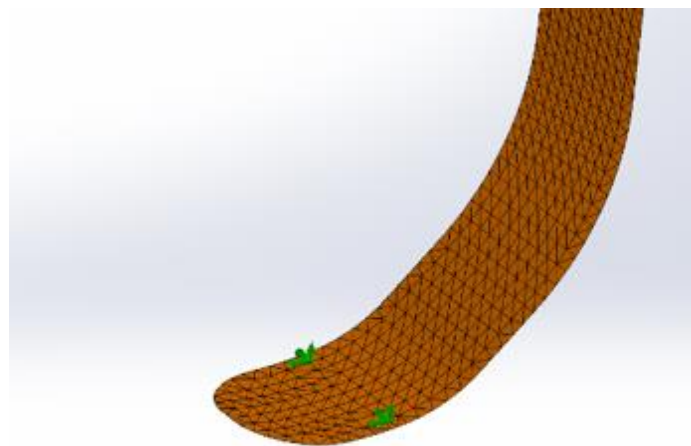
### **Finite Element Analysis**

The Finite Element Analysis models were created to ensure the design will withstand the expected conditions but the models had many assumptions and flaws, this could explain the difference between the test results and the FEA results. The composite component has varying thicknesses, this was very difficult to model accurately in both simulations, to achieve this the crutch was broken down into multiple parts. An issue with the different parts not matching up cleanly for each layer created stress concentrations in the model (Figure 54). This differs for the actual crutch which will be made up of large sheets covering the whole length of the crutch, with a smooth transition over the decreasing thickness.



**Figure 54:** Showing the difference between the different part thickness's of the ANSYS model which differs to the smooth transition in which the real crutch would experience. To improve this the model could be broken down into more parts which will allow a smoother transition of thickness and reduce the chance of singularities.

There was a large difference between the two meshes that were created for each individual software. The Solidworks model created an even mesh over the entirety of the crutch. (Figure 55) The ANSYS model was created using a standard mesh and an inflation over the foot section to allow for greater analysis since this section is most likely to fail. It is assumed that the parts are considered as one single component but the ANSYS software has broken it down into each part with different thickness's, meaning the forces aren't transferred evenly over all layer making the model a more extreme case. (Figure 55).

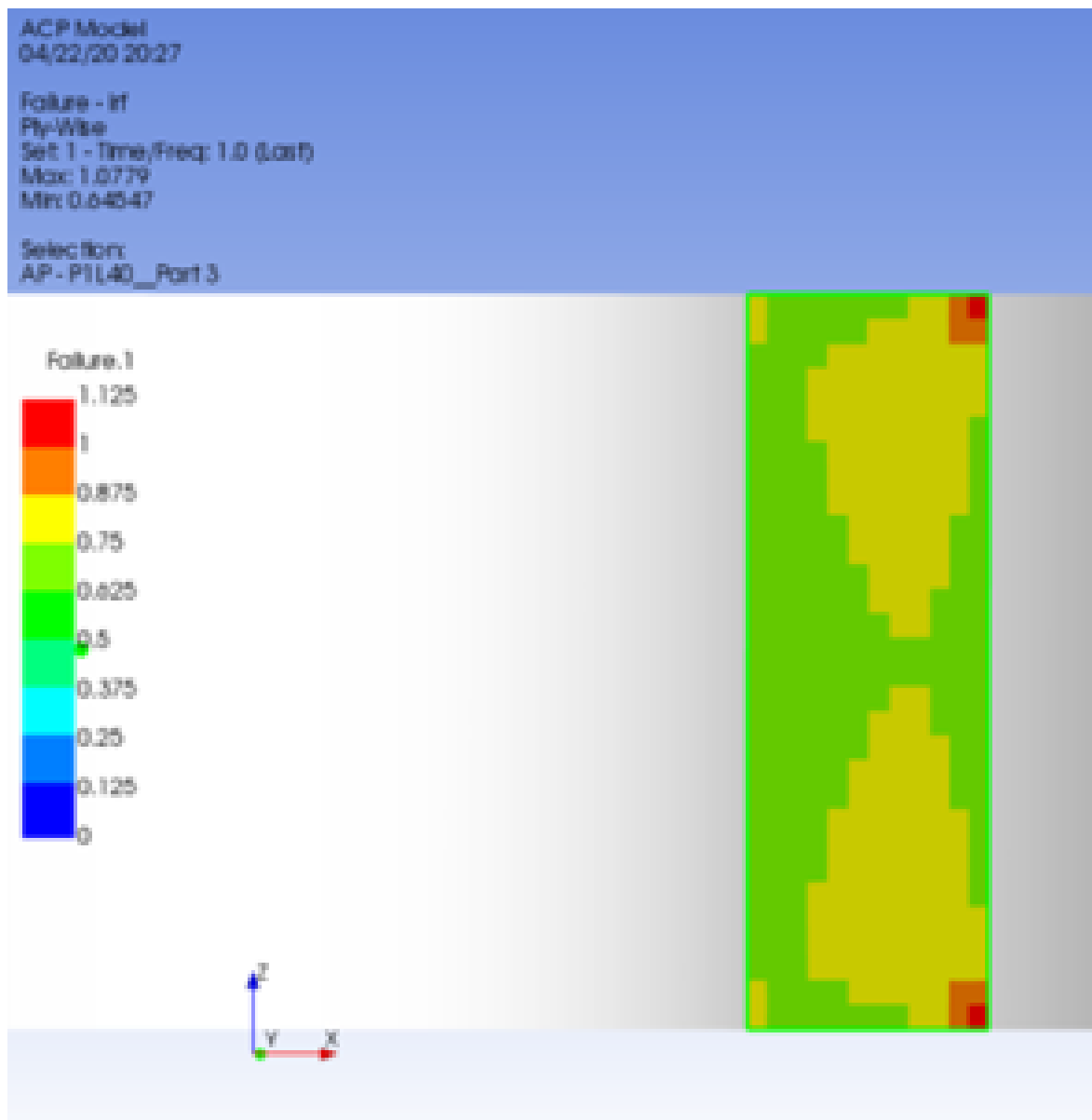


**Figure 55:** Shows the mesh for the Solidworks simulations is consistent over the whole crutch and doesn't show any interaction between the separate parts of the crutch reducing the chances of singularities (although they did occur) these results can therefore be seen as reliable especially when verified with buckling calculations and plate testing results.

Using ACP Post tool on ANSYS to analyse layer by layer was created showing the failure that occurred, this made it clear that the results were heavily affected by the



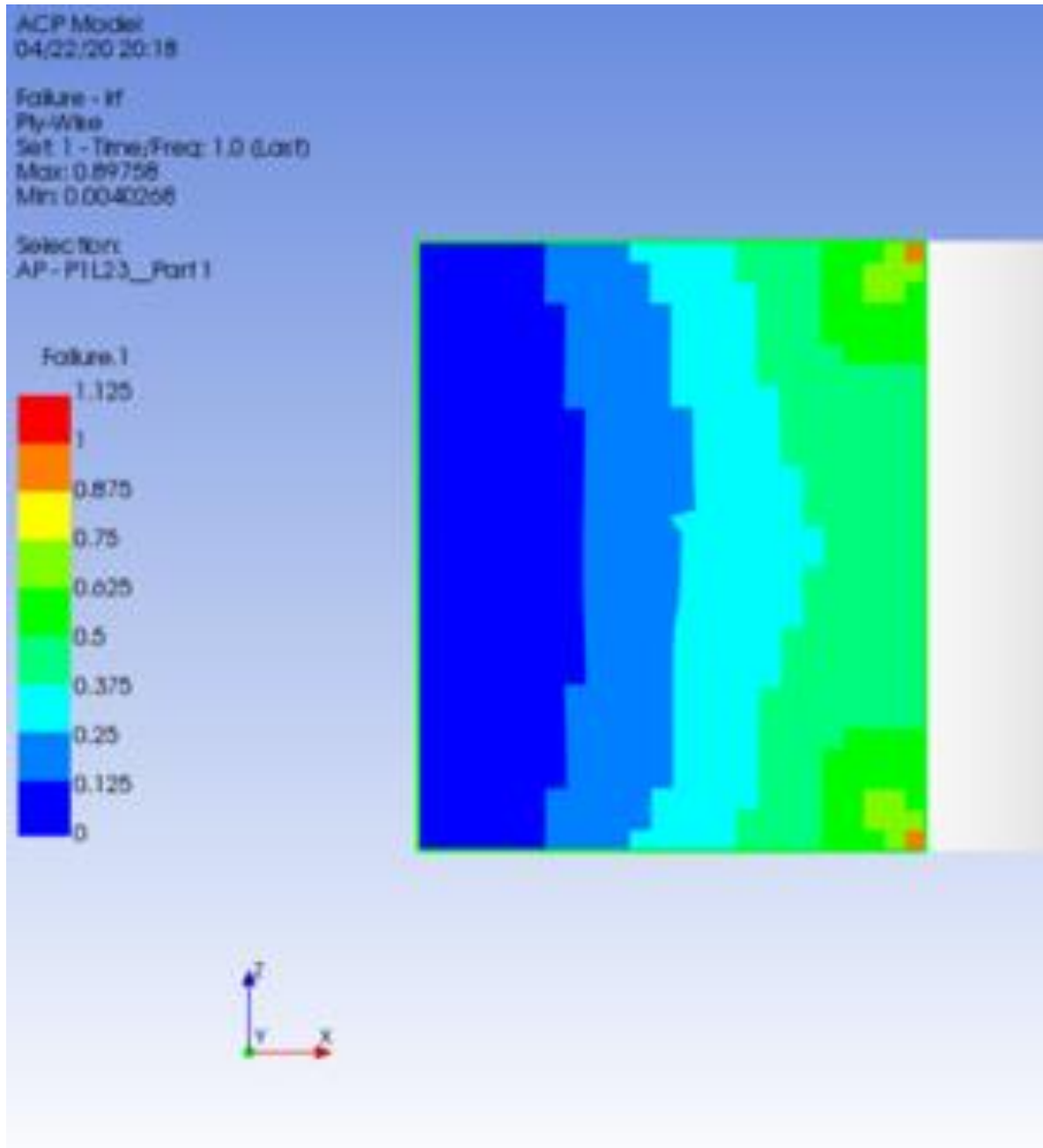
singularities. Figure 56. It was obvious that more extreme results occurred on the edges of the different parts of the crutch, especially around the fixing points off the model. To improve the model it could be broken down into smaller sections, to allow for smaller variation in thicknesses and reduce the chances of singularities. This does not eradicate singularities completely on either software but should reduce the effect it has on the results.



**Figure 56:** Shows the singularity failure points over part 3, Ply 40 can be seen as a reason for FOS being lower than expected. To overcome maximum singularity values a probe could be used to identify the maximum values, any results that could be considered an anomaly's due to an error in the model would be excluded. This can be seen to have the greatest effect on the ANSYS strain results where the values are nearly 10 times higher than expected but with the max values occurring at a single point where the part which is fixed meets the rest of the crutch.

Exaggerated singularity results are seen at the edges or corners of each part, leading to more extreme values occurring, this can be considered as an inaccurate display of what will actually occur in the final product. These values can be identified

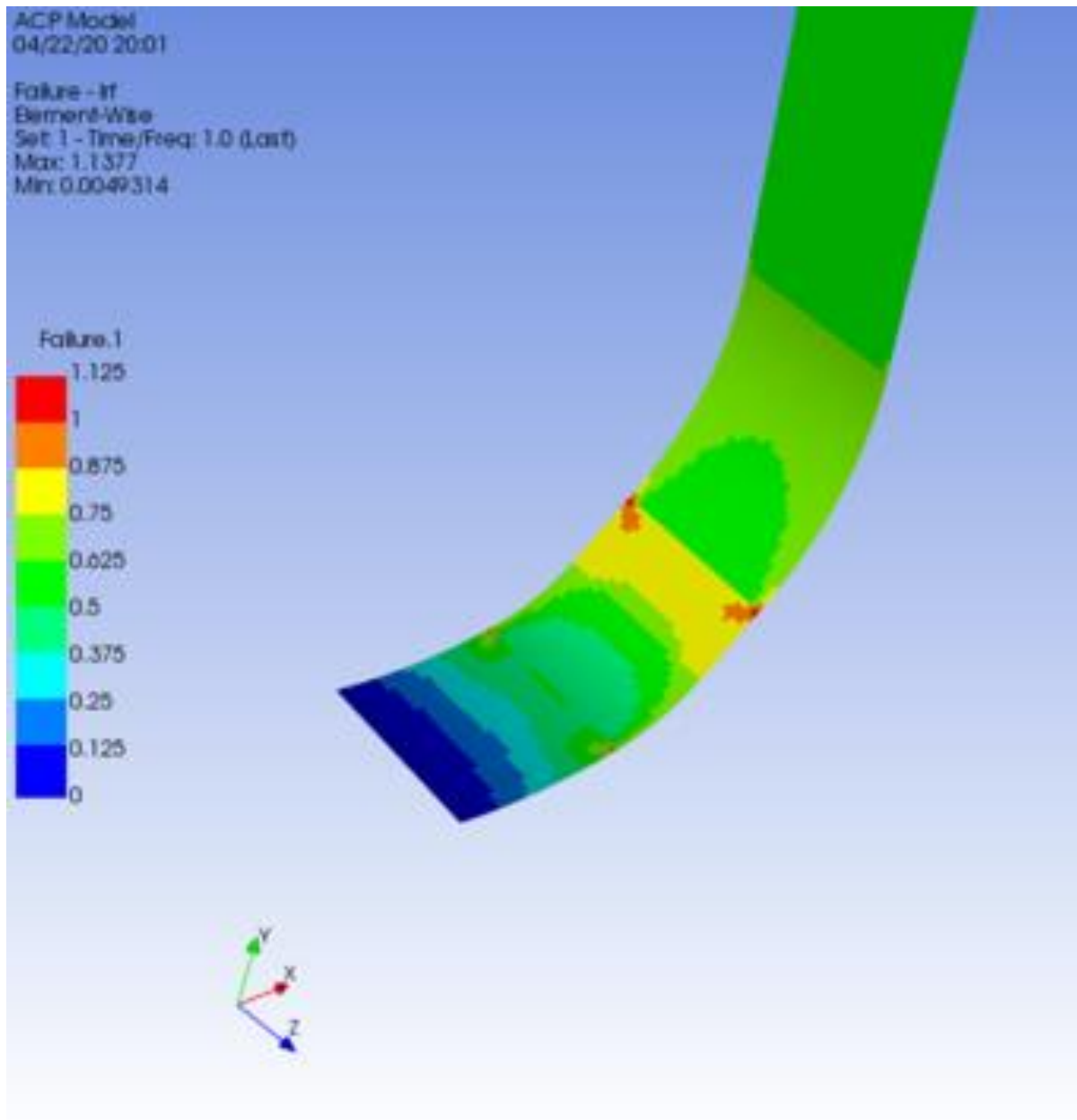
when the mesh density increases and the value increases, trending to infinity, rather than the value stabilising to a consistent value. Figure 57. This can be seen to have the greatest effect on the ANSYS strain results where the values are nearly 10 times higher than expected but with the max values occurring at a single point where the part which is fixed meets the rest of the crutch.



**Figure 57:** Shows the singularity failure points over part 1, Ply 23 can be seen as a reason for FOS being lower than expected. To ensure the extreme failure results were singularities a ply by ply analysis was undertaken for each section ensuring any sections where it suggested failure could be by the set-up, mesh or a singularity difference.

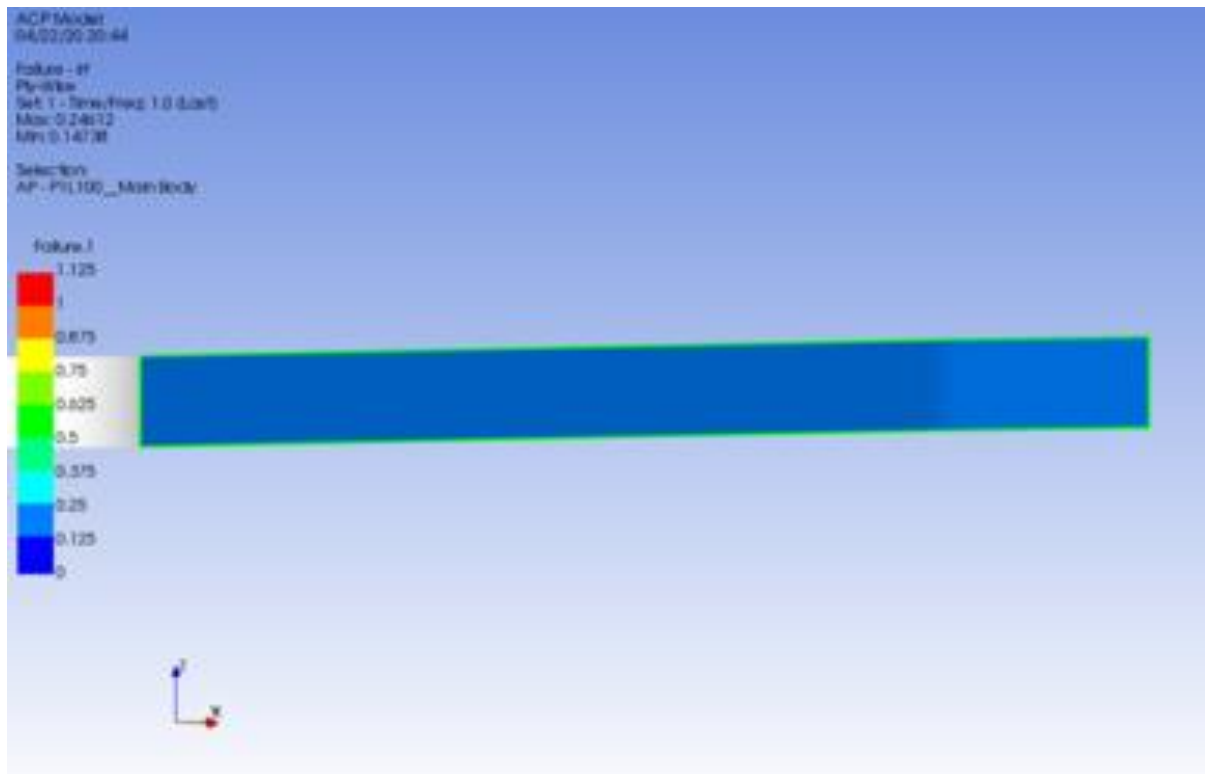
Varying results were seen over the two scenarios. Both with their differing loading and fixing scenarios, with the top scenario considered the most likely to occur but both scenarios are considered not completely accurate. (Figure 57) This can be

explained by the singularities affecting the output results. This can be seen most in the ANSYS model (Figure 58).

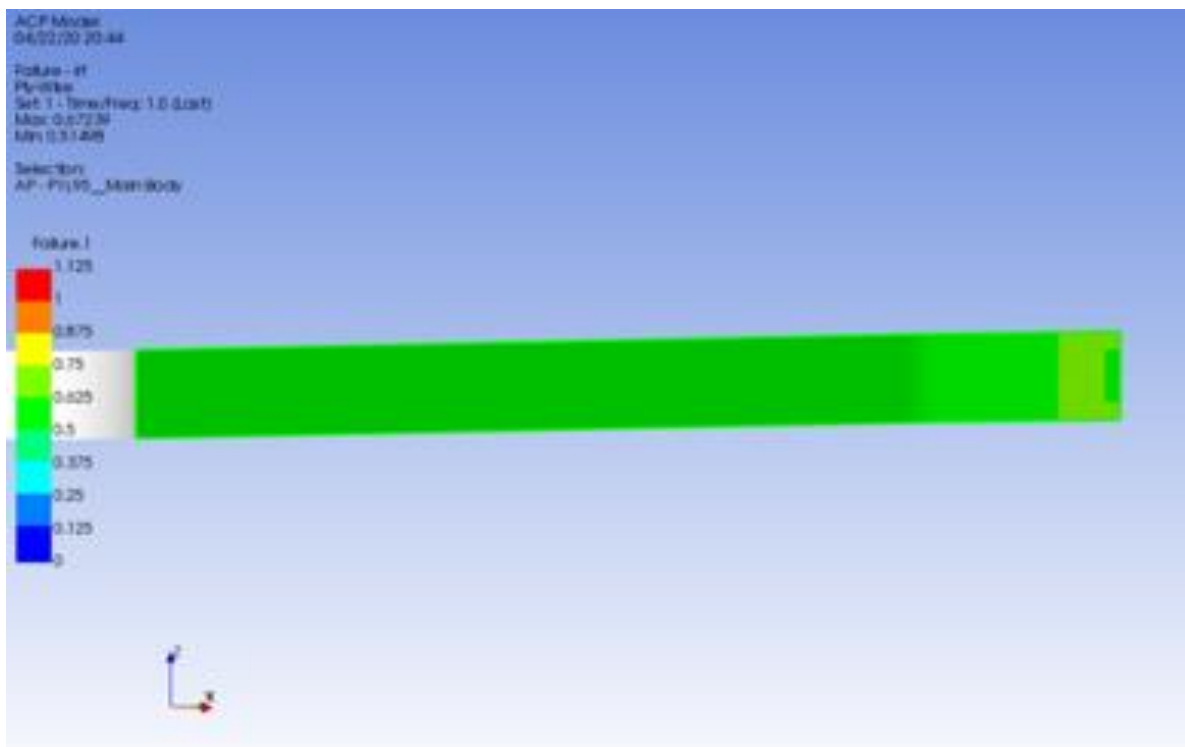


**Figure 58:** Shows that the forces over the crutch can be seen as moderate with a few singularities and hot spots with any spots smaller than several element size to be ignored. The increased singularities in the areas where different thicknesses occurred has meant the FOS of the component had decreased.

Varying results can be seen between the two software's, the main difference being the load cases between the models as previously explained. Along with the singularities these are the biggest influencers. All results show the final design will survive the specified load and therefore deeming the model suitable. An addition of a foam core was considered for this crutch to reduce the weight of the overall design. It was decided that the model had to prove if it could withstand the forces similar to the full composite component before being considered. (Figure 59 & 60)



**Figure 59:** Shows the lowest forces experienced by the crutch main body component. Which is to be expected with the largest forces being experienced at the foot of the crutch where the thinnest sections and most complex geometry occurs.

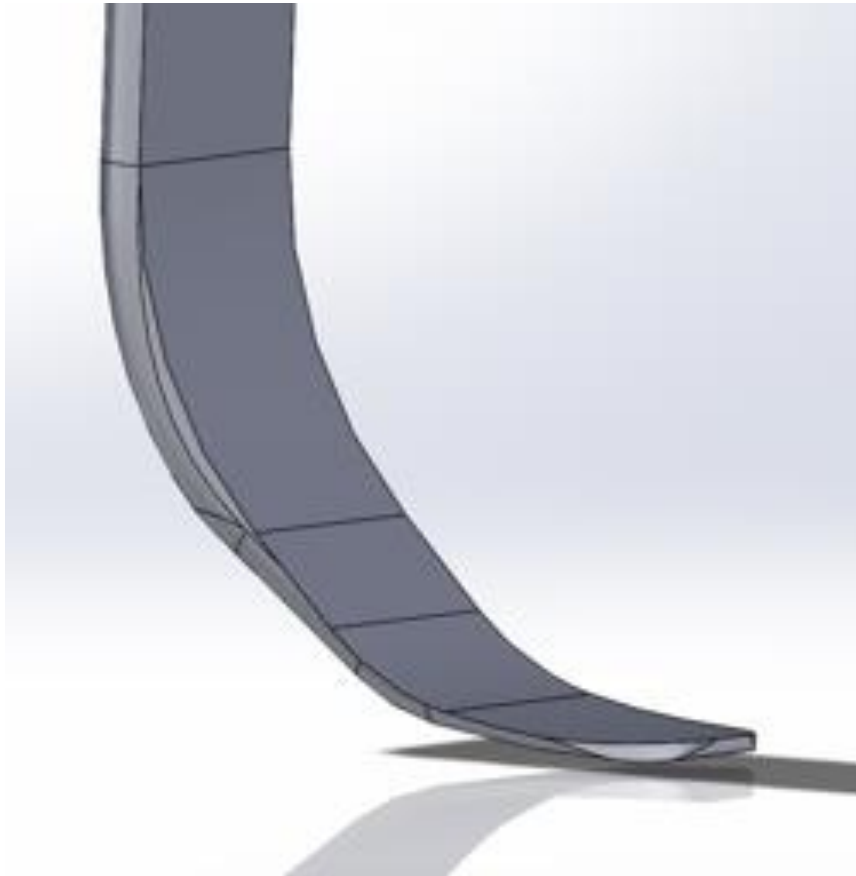


**Figure 60:** Shows the highest forces experienced by the main body component are not considered major but these results cannot be seen as reliable until a test of a full prototype is created and validated the model.

### **Manufacture Alternatives**

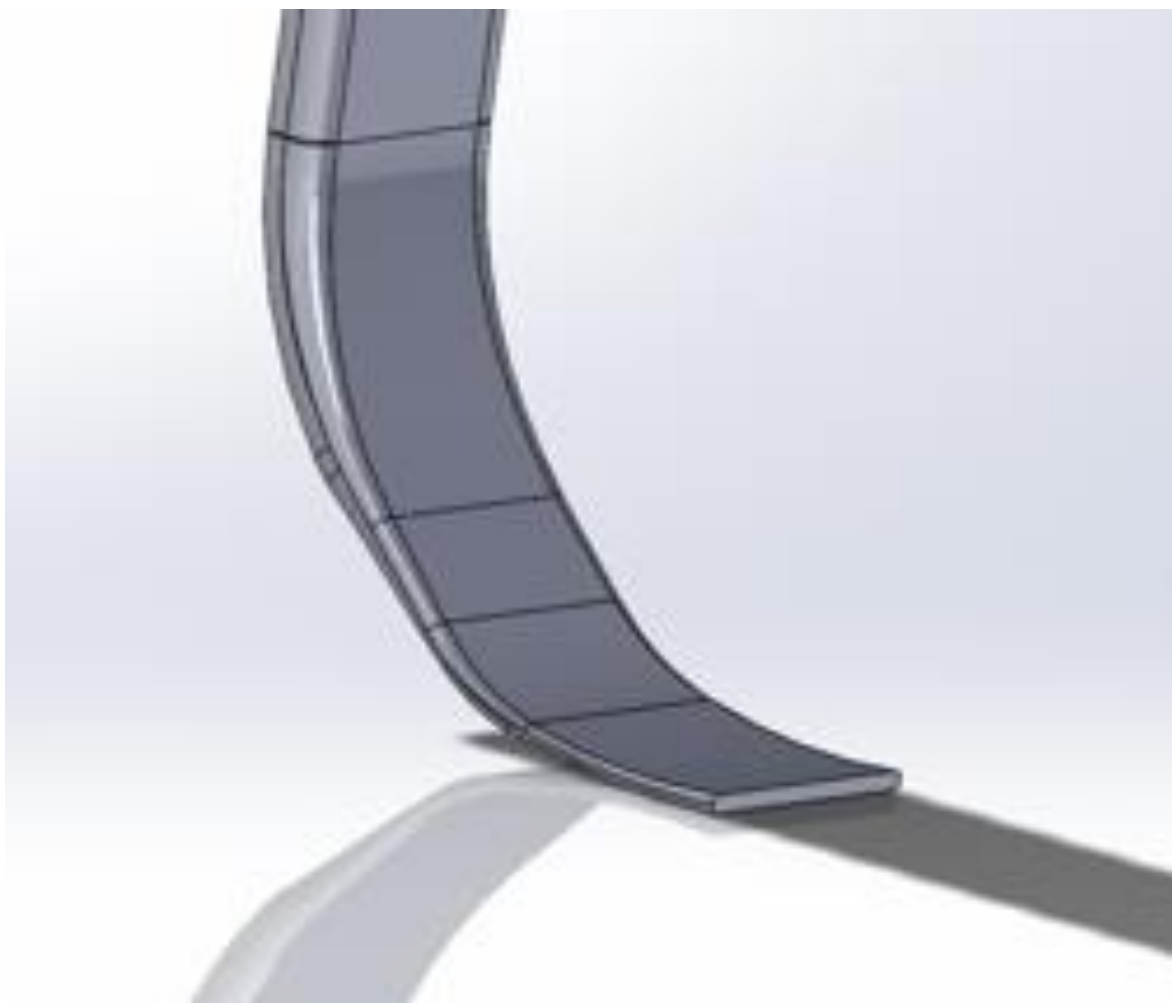
Late on in the project, SHD Composites and Composite Integration discussed options for changing the manufacturing process to reduce the cost of the manufacture.

The production of a composite mould which could withstand the conditions of the curing process of the chosen fibres, would either be completed on university facilities or in partnership with Composite Integration with SHD Composites providing the tooling pre-preg. For this method the design of the crutch had to be altered slightly to match this style of mould, see Figure 61.



**Figure 61:** Showing the change in design to allow the crutch to be produced from pre-preg out of a composite mould tool. The production of the crutch will require an accurate die to produce the composite mould, the mould would cover 3 sides with a shaped aluminium face to be sealed on the front face to ensure good compression and surface finish on all 4 surfaces.

Composite's integration also offered to help with producing the crutch using an industrial RTM method. This method would reduce manufacturing cost of a single component, as well as a lower energy requirement due to the process not requiring an autoclave. The production of a mould using a modelling board would suffice the requirement of producing 5 crutches (2 pairs for the athlete and 1 for destructive testing) and removing the complex process of making a composite mould. This process wasn't chosen before due to the lack of capabilities of the University facilities to produce this method to the standard that was required. The original design of the crutch had to be modified for this method to use a 2-part mould to allow a split line in the middle of the crutch (Figure 62).



**Figure 62:** Showing the change in design to allow the crutch to be produced for a 2 part mould allowing for an alternative production method like RTM. This process will use the same fibres and resin system in the Solidworks model, with Composites Integration also comfortable in achieving the strength characteristics of the pre-preg using their process. Feedback from engineers at Composite Integration advised that all holes should be machined after curing to reduce the complexity of the lay-up process.

### **Costing and Sponsorship**

The costing of this project is very complicated with the different manufacture methods changing the costing model which is dependent on what facilities are available to this project. There are multiple Sponsors and Supporters to this project that include the companies that have already be acknowledge, with the majority of this project will be funded from private benefactors.

### **Conclusion**

A Full set of requirements were created with the athlete which the final design adheres to. From testing with the athlete, it was found that the max force the crutch experiences is 400N which the final design is shown to meet with the weakest model (ANSYS Bottom fixing) shown to fail at 875N. This value is considered to be lower than expected and can be explained by the presence of singularities. To validate these models both first principle calculations and coupon testing methods were used and both showed less than 0.5% difference between the results. The final design will be made by either RTM or Pre-preg, autoclave method as soon as the facilities

become available. Current crutches are designed well for short use (3 months) but possess flaws when being used long term, with the use of custom Hand and Arm supports as well as using composites to reduce weight. The experience for the long term user could be improved and increased price could be justified for the long term user.

### **Future work**

The COVID-19 pandemic was not anticipated at the start of this research and development and has imposed limitations on what could be achieved. Contact with industry specialists, partner companies, the athlete himself and access to all facilities was reduced or terminated respectively. The 2020 Tokyo Paralympic Games has been postponed to July 2021. (IOC, 2020) The final timescale was adjusted to accommodate all the issues experienced over the latter months this was agreed by all parties involved and then once we are able to return to normal production of the crutches will begin. The aim is still to produce a composite crutch for David Wetherill to use at the 2020 Tokyo Paralympic Games. The hope for this project is that the crutch along with the athletes 5 years of training and preparation, will make the new design a contributory factor to the athlete achieving success.

### **Recommendations**

1. Further research into the benefits of the blade crutch. Especially the leaf spring design which should reduce forces through arms and how increase surface area allows for a more stable crutch and can prevent injury of falling.
2. Further development into the composite tube crutch idea to create customised, light weight crutches at low cost for people who use them for extended periods where lightweight and custom supports would benefit recovery.
3. Extending the development of custom Hand Grips and Arm Supports using 3D printing to allow custom pieces to be made to increase comfort for long term crutch users and prevent medical complications.

### **Acknowledgements**

The success of this research project would not have been possible without the supervision, assistance, and encouragement from all those who have been vital in its completion. I would like to thank the following, firstly Professor John Summerscales for assistance and advice throughout the entirety of the project, which has not just allowed me to advance but also ensured the project has remained on schedule. Without the assistance of Professor Long-yuan Li whose knowledge and teachings of stress calculations helped expand my knowledge Dr Maozhou Meng for his assistance in the building and analysis of my Finite Element Analysis models in both Solidworks and Thank the University of Plymouth Technicians notably Dr Richard Cullen, Mr Terry Richards and Dr Jeremy Clark. I would like to thank Garry Scott at the National Composite Centre (furthermore Carbon ThreeSixty Ltd) who provided vital knowledge in 3D printing facilities and materials which could be used for components in the final crutch. Simon Howarth and SHD Composites who have provided vital material data and sample sheets which have allowed for coupon testing. Also, Simon Vincent and Alan Bond at Composite Integration who have provided information on mould design and have offered facilities in the production of the mould and the final crutches. Finally, I would like to thank David Wetherill for firstly inspiring the project but also giving up

his time to participate in the design analysis process and all force experimentation undertaken for this project.

## **Nomenclature**

$\epsilon$  - Strain to failure  
 $\epsilon_A$  - Strain in the vertical axis  
 $\epsilon_B$  - Strain in twist/torsion at 45 Degree angle  
 $\epsilon_C$  - Strain in the horizontal axis  
 $\epsilon_x$  - Strain in x direction  
 $\epsilon_y$  - Strain in y direction  
 $\gamma_{xy}$  - Shear Strain in xy  
 $\eta_d$  - Fibre diameter distribution factor  
 $\eta_l$  - Fibre length distribution factor  
 $\eta_o$  - Fibre orientation distribution factor  
 $\rho_f$  - Fibre density  
 $\sigma_c$  - Composite Strength  
 $\sigma_f$  - Strength of the fibres  
 $\sigma_m$  - Strength of the matrix  
 $\sigma_{ult}$  - Ultimate Tensile Strength  
 $\sigma_x$  - Stress in x Direction  
 $\sigma_y$  - Stress in y Direction  
 $\nu$  - Poisson's ratio  
 $A_f$  - Areal weight of the fabric  
 $b$  - Base of cross-section  
**CAD** - Computer Aided Design  
**COSHH** - Control of substances hazardous to health  
**COV (%)** - Coefficient of variation  
**CPT** - Cured Ply Thickness  
 $d_o$  - Outer Diameter  
 $d_i$  - Inner Diameter  
**E** - Young's Modulus or Tensile Modulus  
 $E_C$  - Tensile Modulus of the composite  
 $E_F$  - Tensile Modulus of the fibre  
 $E_{FLEX}$  - Flexural Modulus  
 $E_m$  - Tensile Modulus of the matrix  
**FOS** - Factor of Safety  
**G** - Shear Modulus  
 $h$  - Height of cross-section  
**I** - Area Moment of Inertia  
**FEA** - Finite Element Analysis  
 $k$  - Fibre area correction Factor  
**ILSS** - Interlaminar shear strength  
**L** - Length of Component  
 $m$  - Slope of the linear proportion of the load/deflection graph  
 $n$  - Number of piles  
**NOTU** - Number of tests undertaken  
**NOVO** - Number of valid observations  
**P** - Load at failure  
**RIFT** - Resin Infusion under Flexible Tooling  
**RTM** - Resin Transfer Moulding  
**S** - Span between supports



## References

Contreras-Vidal, J., A Bhagat, N., Brantley, J., Cruz-Garza, J., He, Y., Manley, Q., Nakagome, S., Nathan, K., Tan, S., Zhu, F. and Pons, J. (2016). Powered exoskeletons for bipedal locomotion after spinal cord injury. *Journal of Neural Engineering*, 13(3), p.031001. [Accessed 23<sup>rd</sup> Sept 2019]

Degaspari, J., 2001. Lightweight Crutches. *Mechanical Engineering-CIME*, 123(1), p.14.

Doll Tepper, G., Kroner, M. and Sonnenschein, W. (2001). *New horizons in sport for athletes with a disability*. Inglaterra: Meyer.

Freddolini, M., Esposito, F., Marcucci, M., Corvi, A., Braccio, P. and Latella, L. (2018). Does crutch length influence gait parameters after total hip replacement surgery?. *Gait & Posture*, 60, pp.262-267. Available at: <http://dx.doi.org/10.1016/j.gaitpost.2017.07.035> [Accessed 23<sup>rd</sup> Sept. 2019].

Genetics Home Reference. (2019). *Multiple epiphyseal dysplasia*. [online] Available at: <https://ghr.nlm.nih.gov/condition/multiple-epiphyseal-dysplasia#genes> [Accessed 4 Dec. 2019].

IOC, 2020. *Joint Statement From The International Olympic Committee And The Tokyo 2020 Organising Committee - Olympic News*. [online] International Olympic Committee. Available at: <<https://www.olympic.org/news/joint-statement-from-the-international-olympic-committee-and-the-tokyo-2020-organising-committee>> [Accessed 25 March 2020].

Ipttc.org. (2019). *ITTF Para Table Tennis Ranking Lists - Men class 6 as of 2019-12-01*. [online] Available at: <https://www.ipttc.org/rating/2019-12-01/M6.htm> [Accessed 1 Dec. 2019].

ISO, 2007. *Example Of An Elbow Crutch*. [image] Available at: <<https://www.iso.org/obp/ui/#iso:std:iso:11334:-1:ed-2:v1:en>> [Accessed 20 April 2020].

Leonard, J. (2019). *Mobility aids: Types, benefits, and use*. [online] Medical News Today. Available at: <https://www.medicalnewstoday.com/articles/318463.php> [Accessed 8 Dec. 2019].

Medline Plus (2019). *Mobility Aids: MedlinePlus*. [online] Medlineplus.gov. Available at: <https://medlineplus.gov/mobilityaids.html> [Accessed 8 Dec. 2019].

National Paralympic Heritage Trust. (2019). *Table Tennis*. [online] Available at: <https://www.paralympicheritage.org.uk/table-tennis> [Accessed 6 Dec. 2019].

Noroozi, S., Sewell, P., Rahman, A., Vinney, J., Chao, O. and Dyer, B. (2012). Modal analysis of composite prosthetic energy-storing-and-returning feet: an initial investigation. *Proceedings of the Institution of Mechanical Engineers, Part P: Journal of Sports Engineering and Technology*, [online] 227(1), pp.39-48. Available at: <https://doi.org/10.1177/1754337112439274> [Accessed 3 Dec. 2019].

Potter, B. and Wallace, W., 1990. Crutches. *BMJ*, [online] 301(6759), pp.1037-1039. Available at: <[https://www-jstor-org.plymouth.idm.oclc.org/stable/29709423?seq=1#metadata\\_info\\_tab\\_contents](https://www-jstor-org.plymouth.idm.oclc.org/stable/29709423?seq=1#metadata_info_tab_contents)> [Accessed 20 February 2020].

Raikin, S. and Froimson, M. (1997). Bilateral Brachial Plexus Compressive Neuropathy (Crutch Palsy). *Journal of Orthopaedic Trauma*, 11(2), pp.136-138. [Accessed 20<sup>th</sup> Nov. 2019]

Running blades rely on composites. (2012). *Reinforced Plastics*, 56(5), p.17. [Accessed 17<sup>th</sup> Nov. 2019]

Sala, D., Leva, L., Kummer, F. and Grant, A. (1998). Crutch handle design: Effect on palmar loads during ambulation. *Archives of Physical Medicine and Rehabilitation*, 79(11), pp.1473-1476. [Accessed 16<sup>th</sup> Sept. 2019].

Scholz, M., Blanchfield, J., Bloom, L., Coburn, B., Elkington, M., Fuller, J., Gilbert, M., Muflahi, S., Pernice, M., Rae, S., Trevarthen, J., White, S., Weaver, P. and Bond, I., 2011. The use of composite materials in modern orthopaedic medicine and prosthetic devices: A review. *Composites Science and Technology*, [online] 71(16), pp.1791-1803. Available at: <<https://www.sciencedirect.com/science/article/pii/S0266353811003071#b0430>> [Accessed 20 February 2020].

Simplify 3D, 2020. *Ultimate 3D Printing Materials Guide | Simplify3d*. [online] Simplify3d.com. Available at: <<https://www.simplify3d.com/support/materials-guide/>> [Accessed 3 May 2020].

Solidworks - Materials Library. (2017). Vélizy-Villacoublay, France: Dassault Systèmes. [Accessed 8<sup>th</sup> Dec. 2019]

Wu, T., Soni, S., Hu, M., Li, F. and Badiru, A. (2011). The Application of Memetic Algorithms for Forearm Crutch Design: A Case Study. *Mathematical Problems in Engineering*, 2011, pp.1-14. [Accessed 12<sup>th</sup> Sept 2019]

Zhang, Y., Liu, G., Xie, S. and Liger, A. (2011). Biomechanical Evaluation of an Innovative Spring-Loaded Axillary Crutch Design. *Assistive Technology*, [online] 23(4), pp.225-231. Available at: <https://doi.org/10.1080/10400435.2011.614676> [Accessed 8 Dec. 2019].

### **Equations**

[1] Benham, P. and Crawford, R. (1996). *Mechanics of engineering materials*. Harlow, Essex, England: Longman Group, pp.292-302.

[2] Benham, P. and Crawford, R. (1996). *Mechanics of engineering materials*. Harlow, Essex, England: Longman Group, pp.292-302.

[3] Benham, P. and Crawford, R. (1996). *Mechanics of engineering materials*. Harlow, Essex, England: Longman Group, pp.292-302.

- [4] Benham, P. and Crawford, R. (1996). *Mechanics of engineering materials*. Harlow, Essex, England: Longman Group, pp.292-302.
- [5] Curtis, PT. CRAG Test Methods for the Measurement of the Engineering Properties of Fibre Reinforced Plastics, *Royal Aerospace Establishment Technical Report 88 012*, February 1988.
- [6] Anderson, JC., Leaver, KD., Alexander, JM. and Rawlings, RD. (1974) *Materials Science*. 2<sup>nd</sup> edn. Sunbury-on-Thames: Thomas Nelson & Sons.
- [7] Kelly, A. and Tyson, W., 1965. Tensile properties of fibre-reinforced metals: Copper/tungsten and copper/molybdenum. *Journal of the Mechanics and Physics of Solids*, 13(6), pp.329-350.
- [8] Curtis, PT. CRAG Test Methods for the Measurement of the Engineering Properties of Fibre Reinforced Plastics, *Royal Aerospace Establishment Technical Report 88 012*, February 1988.
- [9] AS Virk, W Hall and J Summerscales, Modulus and strength prediction for natural fibre composites, *Materials Science and Technology*, July 2012, 28(7), 864-871.
- [10] Curtis, PT. CRAG Test Methods for the Measurement of the Engineering Properties of Fibre Reinforced Plastics, *Royal Aerospace Establishment Technical Report 88 012*, February 1988.
- [11] Al-Dwairi, Z., Tahboub, K., Baba, N. and Goodacre, C., 2018. A Comparison of the Flexural and Impact Strengths and Flexural Modulus of CAD/CAM and Conventional Heat-Cured Polymethyl Methacrylate (PMMA). *Journal of Prosthodontics*, 29(4), pp.341-349.
- [12] Benham, P. and Crawford, R. (1996). *Mechanics of engineering materials*. Harlow, Essex, England: Longman Group, pp.292-302.

[13] Delmonte, J., 1981. *Technology Of Carbon And Graphite Fiber Composites*. New York: Van Nostrand Reinhold, p.318.

[A,B,C,DE] Benham, P. and Crawford, R. (1996). *Mechanics of engineering materials*. Harlow, Essex, England: Longman Group, pp.292-302.

**Standards**

British Standards Institution (1998) *BSEN14125:1998+A1:2011: Fibre-reinforced plastic composite – Determination of flexural properties*. Available at:

<https://shop.bsigroup.com/ProductDetail/?pid=000000000030219524> (Accessed: 20<sup>th</sup> February 2020)